

Clay Works & Inspira- tions

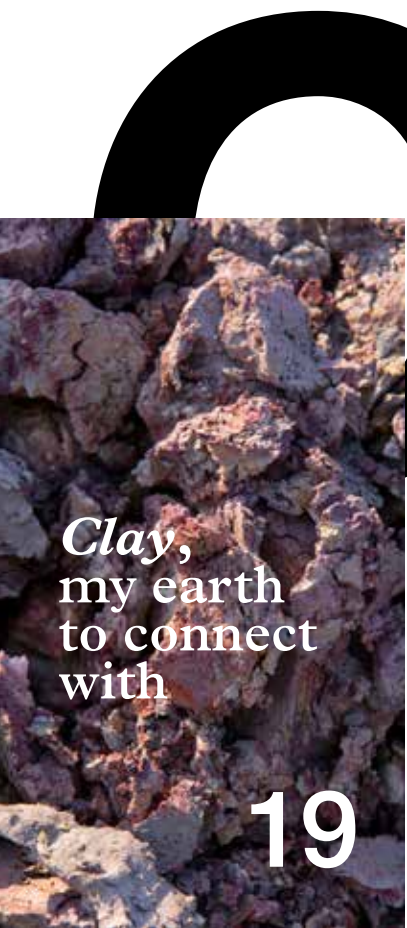

 Element Green®
Ihr Netzwerk für Raumbegrünung





*Clay,
my earth
to connect
with*

19

All photography:
Bart Van Leuven
bartvanleuven.com
unless other specified.



73

*Clay
colours,
textures,
finishes*



155

*Clay
Labora-
tories*



219

*Clay,
Heritage
— Nature
of home*



*Clay, my
connection
to the world
— Durable
items made
by happy
people*

443

Lay-out:
wimvandersleyen.com

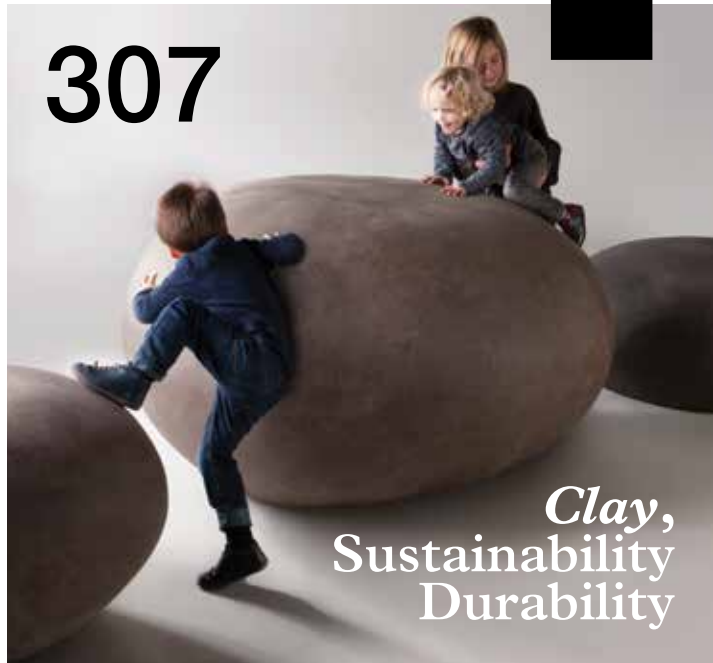

307

*Clay,
Sustainability
Durability*



363

*Custom and
on demand
Clay projects*



Kåseholm
Slott

539

Content Collections

A

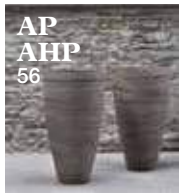
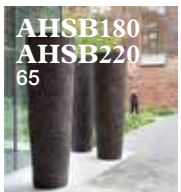

B





BM
140



BS
146



BP
148



BR
149

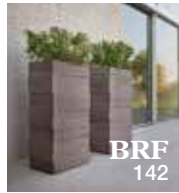

BRF
142



BRL
150



CK CKB
186



CKL
188



CLG
200



CBH
176



BTV
154



BZ
171

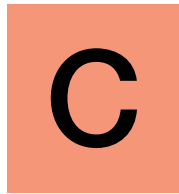

C



CBH180
175



CLK
204



CLO50
206



CLT
211



CL
190



C
597



CLS
210



CLO80
207



CS
216



CLB
194



CB
174



CC50
180



CLE
198



CLE
196



CCL
182



COP
212



CS
214



CS
216



CV
228

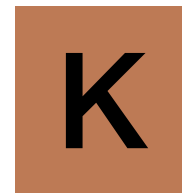
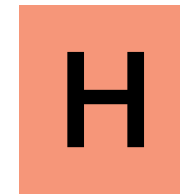
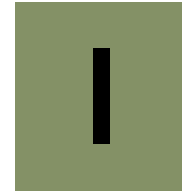



KHO
316



KKA
319



KKB
322



KKC
323



KX
324



KL
292



LR
332



LPS
330



LC
328



LPS100
331



LRC
334



M
340



MA
341



MF
342



MH
343



ML
352



MHR
344



MK
345



MLH
350



MLH Bench
348



MLS
354



MR
356



MRR
384



MRB
378



MRO
382



MRA
360



MU
385



MUR
387

O

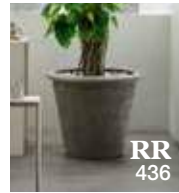
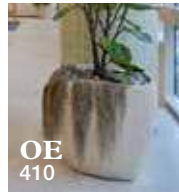

P



S



R





SP
474



SR
494



SRS
502



UFS
544



UK
548



UKL
552



UG
543



UH
546



SRD
498



TAH
508



SY
SYD
504



UO
554



UM
560



UP
562



UR
564



TA
506



TP
512



TW
514



US
580



TM
290



UZ
582

UQ
563

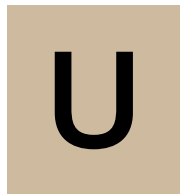

UC
528



U
516



UDS
529



UE
530



UB
526



UF
534



UT
561

V



W



Clay,
my earth
to connect
with



Z



— In Europe’s heartland Germany, big rocks of clay deposits are dug out of the ground. Trucks come and go, cranes carve into the soil and extract blocks of earth, aged in the time and transformed to clay, coloured through natural oxides deriving from processes in nature. As a natural material, clay is a finely-grained natural rock or soil material that combines one or more minerals with possible traces of metal oxides and organic matter. Geologic clay deposits are mostly composed of phyllosilicate minerals containing variable amounts of water trapped in the mineral structure. Depending on the nature of the soil in which it is found, clay can appear in various colours, from white to dull grey, from brown to deep orange-red. This is because the physical features of the clay mineral present in any particular soil depend on many variables such as parent material, climate, the geographic position of the quarry, the surrounding vegetation and the length of time over which these factors have operated.

Clay, my earth to connect with





Clay, my earth to connect with

— Clays are distinguished from other fine-grained soils by differences in size and mineralogy. Many different types of clays can be found in nature and they are classified according to their mineral composition and properties. Chamotte, known as calcined kaolin, is the most used variety of clay for manufacturing. In fact, chamotte can be defined as a ceramic raw material characterized by a high percentage of silica and alumina. It can be produced by firing selected clays to high temperature, which are then grinded to specific particle sizes. For this reason, it seems to have «small rocks» inside its texture. It tends to be porous and with a low density. Specifically, it is composed by 40% alumina, 30% minimum silica, 4% maximum Iron oxide, 2% maximum of calcium oxide and magnesium oxide combined together. Its composition forms an ideal basis for further processing typical of ceramic products, such as firing. Moreover, its peculiar composition eases the drying process and prevents excessive shrinkage and defects such as cracking. The coarse particles open the clay body to allow gases to escape.

— Clay has many properties such as high plasticity, shrinkage during drying and firing and impressive hardness after being fired. When still wet, it can be molded to form a shape that it retains while drying. During the drying process, clay loses its original plasticity. However, the clay can still be treated with water so that the shape can still be partially altered. Once the clay is dry, it becomes hard and not pliable and it is ready to be fired to become bisque. Bisque is the name used to define all types of clays that have been fired to become a ceramic. It is different from non-fired clay as it undergoes chemical changes during the firing process: in fact, bisque turns into a permanent shape and cannot be altered anymore. Firing also alters the size of the object made with clay, as the heat eliminates all the water particles trapped in the structure of clay so that the object is subjected to shrinkage.

— Since their first steps, people acquire knowledge through all their senses: in fact, being human means most of all to be alive with all these senses: how we listen, how we taste, how we touch. In our digital world, this kind of knowledge has become more and more important. There is a real need for people to connect with what they can learn from their senses. As a universal prime material, Clay has the power to connect people from across the globe. How can we describe the origins of such connection between the human being and clay? The religious narrative also mentions that man was created with clay. The relation goes back beyond memory, trillion of years ago, when there was Chaos, from which all living species were created: volumes and mass of material floated randomly in space colliding, breaking into smaller particles and eventually aggregating in bigger entities. Planet Earth and eventually Life were born due to such collisions. The unconscious memory of our origins remains in our nature and, throughout history, it has led humans to relate with clay in different ways: from its use as a building material to its use in pottery and in traditional medical treatments, clay has always been used in the material world we live in. Used by artists, potters, ceramists, there has been an endless rethinking of the use and applications of clay throughout history; from antique Chinese porcelain to

today's contemporary vessels, Clay has been continuously put into question and has been used as the preferred medium to express and vehiculate knowledge.

— Prehistoric humans were the first to discover the useful properties of clay. Some of the earliest pottery shards recovered are located in Japan and they are related to the Jōmon. Clay tablets were also the first known writing medium in history. In the ancient cultures which lived in the Mesopotamian and Mediterranean areas, public figures like scribes used to register information by inscribing cuneiform script on clay surfaces. Clays sintered in fire were the first form of ceramic: bricks, cooking pots, art objects, cutlery and even musical instruments could, in fact, all be shaped from clay.

— As building material, Clay is one of the oldest on Earth, together with stone and wood. Between one-half and two-thirds of the world's population in both traditional societies and developed countries still live or work in buildings made with clay, and they often use it for daily necessities.

— Nonetheless, clay has also covered and still covers nowadays a remarkable role in traditional medicine, thanks to its healing properties. In fact, the traditional uses of clay as medicine goes back to prehistoric times. Nowadays Clay is also used in many industrial processes such as paper making, cement production, and chemical filtering.

— This 'interwoven', everyday knowledge survives through the fired objects and clay shapes. Since the 60's and 70's of the past century, the rise of industrialized production processes has reduced the quality of what people daily consume in favor of ready-to-use commodities. The reduction of the time of preparation and the increase in the efficiency of production processes made commodities of daily use available for millions of people. However, traceability went lost, and the cost minimization became the basis of the current industrial supply chain: the less expenses, the better. As human nature is flexible, a counter movement came up – for example, the whole food revolution developed in the food sector, where communities started to grow their own vegetables and keep their own animals. The gastronomic fascination about what we

Clay, my earth to connect with



use to feed ourselves is one of the biggest counter revolution in the worlds history and shows the critical nature of human beings; taking distance of programmed food processing as an act of cultural rebellion. In the same perspective, we have become extremely sensitive to the materials that play a crucial role in our daily life: the sofa we rest on, the chair we sit on and the table work and dine on. We feel, touch and use throughout everyday materials – carpet, books, cushion, walls – that make us feel happy – materials we can connect with. With this move away from ‘fake’ materials like plastic, composite, that are not what they pretend to be, towards materials that are what they are - wood, glass, metal, clay- people go back to their origins, to their roots.

Clay, my earth to connect with



A

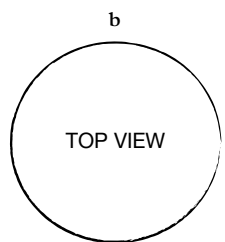
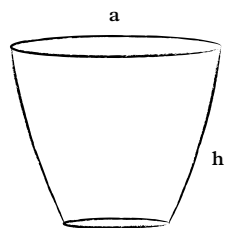

	a	b	h	w	m ³
A40	47cm	23cm	40cm	20kg	27,5l
A50	56cm	25cm	49cm	30kg	52l
A60	70cm	35cm	60cm	40kg	108,5l
A70	75cm	40cm	70cm	55kg	150,5l
A80	88cm	48cm	81cm	70kg	246,1l
A90	99cm	53cm	91cm	100kg	398,9l
A100	110cm	58cm	101cm	135kg	526l
A110	120cm	62cm	110cm	180kg	704l
A120	130cm	70cm	120cm	200kg	880l

A40	18,5"	9"	15,7"	45lbs	7,3gal
A50	22"	9,8"	19,3"	65lbs	13,7gal
A60	27,5"	13,8"	23,6"	90lbs	28,7gal
A70	29,5"	15,7"	27,5"	120lbs	39,8gal
A80	34,6"	18,9"	31,9"	155lbs	65gal
A90	39"	20,9"	35,8"	220lbs	105,4gal
A100	43,3"	22,8"	39,8"	297lbs	139gal
A110	47,2"	24,4"	43,3"	396lbs	186gal
A120	51,2"	27,6"	47,2"	440lbs	232,4gal

For the top terraces of the Bohemia Hotel on Playa del Inglés, Tenerife, Spanish landscape architect Luis Vallejo selected **A80** vases in black anthracite planted with palm trees.

A



In and around the *Philosofia*, the bar at Barcelona's *Sofia Hotel*, groups of **A** vases at different heights and in various grey shades, planted with *Myrtus communis*, *Westringia fruticosa*, *Verbena bonariensis*, *Metrosideros excelsa* and *Acer campestre*, create intimate spaces on the terrace for guests enjoying a coffee in the early morning sunlight. While in London's *St Pancras* urban development, larger **A80** and **A120** models are put along *Stable Street*, to create a green walk way from *Granary* to *Lewis Cubitt Square*.

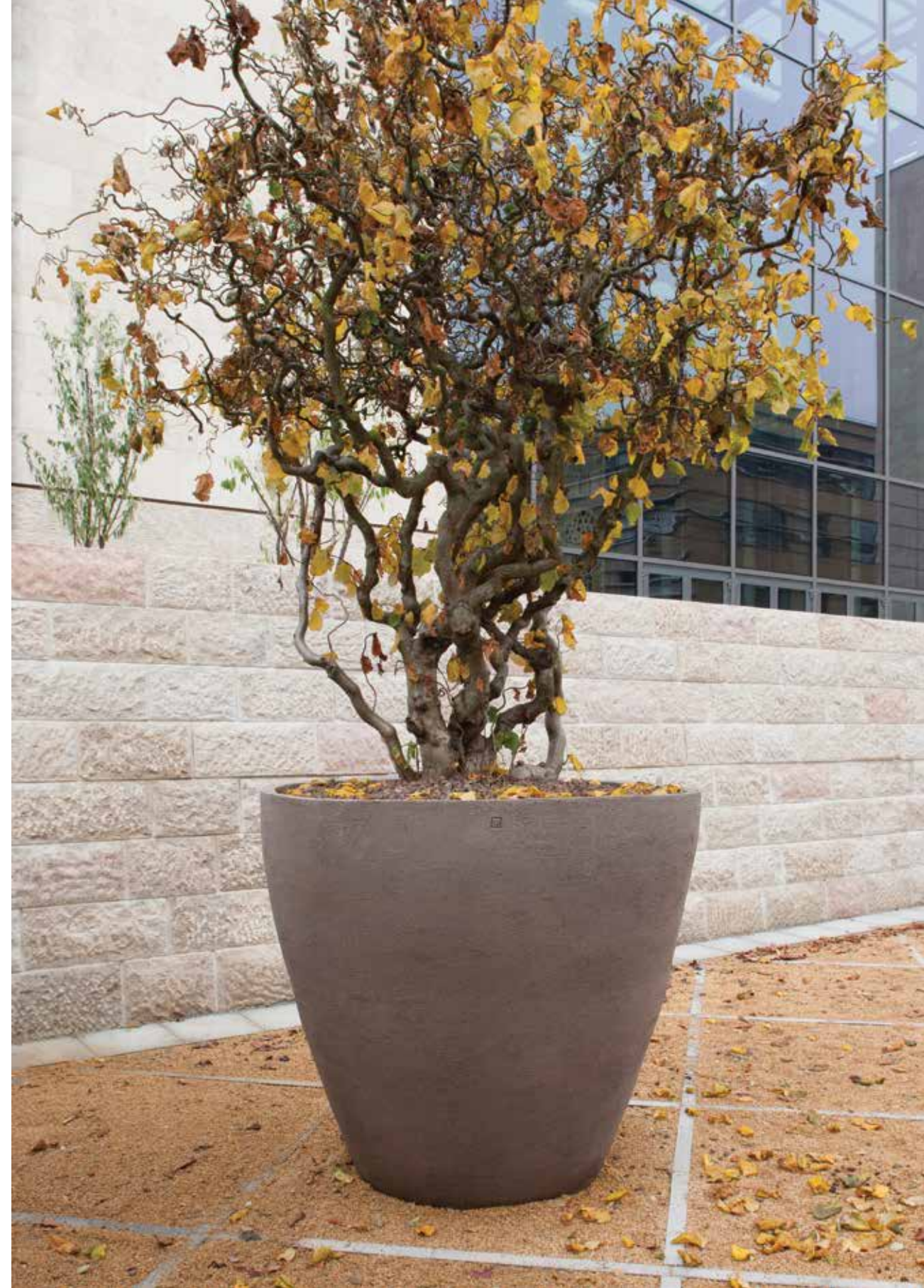



A80

A120

For King's Cross, Dan Pearson landscape architects positioned small groups of **A** planters a long Stable Street in order to create islands that guideline the visitor from one shop or restaurant to another. The more attractive the different areas are, the bigger the interaction between people becomes.



A120 and **A80** vessels along the Laagte Kadijk, in front of former brewery Stout & Co, transformed into Delva Landscape Design practice and stylish B&B.



A60 and **A50** in grey taupe color at Sagg Pond residences, Long Island, NY

AB

	a	b	h	w	m ³
AB40	47cm	23cm	40cm	20kg	27,5l
AB50	56cm	25cm	49cm	30kg	52l
AB60	70cm	35cm	60cm	40kg	108,5l
AB80	88cm	48cm	81cm	75kg	246,1l

AB40	18,5"	9"	15,7"	45lbs	7,3gal
AB50	22"	9,8"	19,3"	65lbs	13,7gal
AB60	27,6"	13,8"	23,6"	88lbs	28,7gal
AB80	34,6"	18,9"	31,9"	165lbs	65gal

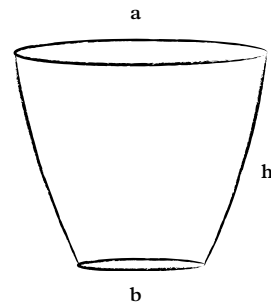

**Following bark textures
are possible:**
White clay with grey texture
Grey clay with black texture
Black clay with red texture
Red clay with black texture

AB80's in warm Bordeaux red color are used in Westfield Village in Woodland Hills. The Village's welcoming and casually elegant environment typifies our Southern California lifestyle and offers a walkable, car-free space unlike any other in the local community.



AB80, AB60 and AB50 grey with black accents Bohemia Hotel, Gran Canaria.



AH

	a	b	h	w	m ³
AH50	29cm	17cm	49cm	15kg	14l
AH65	37cm	20cm	64cm	20kg	30l
AH90*	42cm	26cm	90cm	35kg	75l

AH50	11,4"	6,7"	19,3"	35lbs	3,7gal
AH65	14,6"	7,9"	25,2"	45lbs	7,9gal
AH90*	16,5"	10,2"	35,4"	77lbs	19,8gal

*Suitable
for a polyester
innerliner.

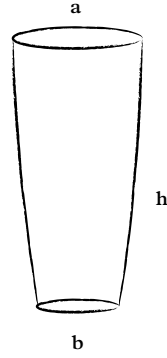

AH90 Grey at Postfinance,
Bern, Switzerland

Since more than hundred years Gstaad is well known for exclusive Mountain holidays and a relaxed life style. Refined music, wine and mountain gastronomy lie at the heart of Gstaad society. Artisans retain traditional skills while farmers live off the pastures just like their fore-fathers. Such elegant authenticity was what drew pioneering sport enthusiasts to the region all those years ago. Now it is the turn of The Alpina to define an era while celebrating the vibrant core of Saanenland culture. For the terraces outside and around the swimming pools, **HBA** chose **A80** and **AH90** vases in black anthracite clay planted with multicolor geranium flowers.



AH130 Private Villa,
Palm Springs, CA



AH130

	a	b	h	w
AH130	72cm	34cm	127cm	90kg
AH130	28,3"	13,4"	50"	200lbs



AH

	a	b	h	w
AH140	60cm	45cm	140cm	90kg
AH180	88cm	53cm	180cm	150kg
AH220	100cm	65cm	226cm	250kg
AH140	23,6"	17,7"	55,1"	198,lbs
AH180	34,6"	20,8"	70,8"	330lbs
AH220	39,3"	25,5"	88,9"	551lbs

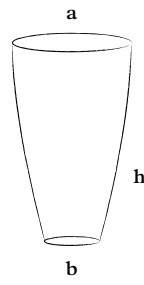

AH220 planted with
Dracaena surcullosa
at Rives D'Arcins,
Bordeaux



AH220 in black,
New Zebra, Ghent





Hotel Marignan Paris five star is ideally located at 12 Rue de Marignan, a quiet street in the 8th Arrondissement, which connects the Champs-Elysees and the Avenue Montaigne, Mecca of Parisian shopping, in the center of the famous 'Triangle d'Or' of Paris. As the hotel sits only steps away from the Grand Palais as well as from many prestigious art galleries, its address has a natural association with both art and culture. The interior architect Pierre Yovanovitch, icon of New French Style, transformed the Hotel Marignan Paris into an island of contemporary luxury, a serene and confidential stop in the heart of the capital. For the entrance, the owners of the hotel have opted for black anthracite **AHS** and **CBH** vases, and some smaller **ZB** seats along the façade.

CBH180

AHS220

AHC

	a	b	h	w
AHC	62cm	34cm	136cm	90kg
AHC	24,4"	13,4"	53,5"	200lbs

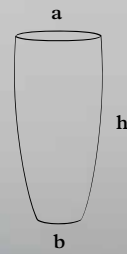

R/Z21/V5

W/C14

G/C14



AHT140
W/C (POS) HALF

AHT140
W/C (NEG)

AHT140
G/C (POS)

AHT140
Z/R (NEG)

AHT



	a	b	h	w
AHT	62cm	34cm	136cm	90kg
AHT	24,4"	13,4"	53,5"	200lbs

AHE

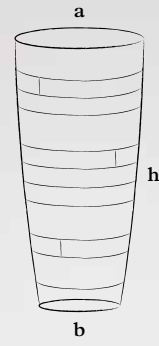

G/Z21

G/R12



	a	b	h	w
AHE90	42cm	26cm	90cm	35kg
AHE90	16,5"	10,2"	35,4"	77lbs

W/G19

Z/R12

AHO

	a	b	h	w
AHO90	42cm	26cm	90cm	40kg
AHO140	60cm	45cm	140cm	100kg
AHO90	16,5"	10,2"	35,4"	88lbs
AHO140	23,6"	17,7"	55,1"	220lbs

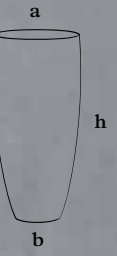

AHP

AP

	a	b	h	w
AP40	47cm	23cm	40cm	20kg
AP80	89cm	49cm	81cm	80kg
AHP90	70cm	35cm	97cm	90kg
AHP130	73cm	35cm	127cm	120kg

AP40	18,5"	9"	15,7"	45lbs
AP80	35"	19,3"	31,9"	175lbs
AHP90	27,6"	13,8"	38,2"	200lbs
AHP130	28,7"	13,8"	50"	265lbs

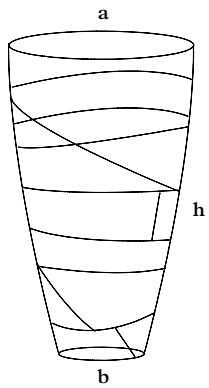

AHS180 AHS220

	a	b	h	w
AHS180	61cm	42cm	180cm	200kg
AHS220	70cm	50cm	220cm	300kg
AHS180	24"	16,5"	70,8"	440lbs
AHS220	27,5"	19,6"	86,6"	661lbs

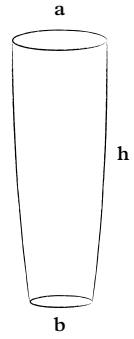

AHB180 AHB220

	a	b	h	w
AHB180	61cm	42cm	180cm	200kg
AHB220	70cm	50cm	220cm	300kg
AHB180	24"	16,5"	70,8"	440lbs
AHB220	27,5"	19,6"	86,6"	661lbs

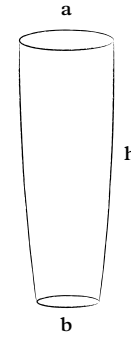



Departure Hall,
Zurich Airport

AHS180

AHS220

AHSB180 AHSB220

	a	b	h	w
AHSB180	61cm	42cm	180cm	200kg
AHSB220	70cm	50cm	220cm	300kg
AHSB180	24"	16,5"	70,8"	440lbs
AHSB220	27,5"	19,6"	86,6"	661lbs



AHT140 - R/Z
(NEG)

AHS180 - Z/R
(NEG) + T16

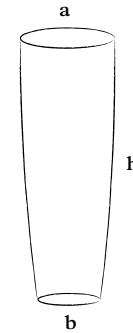

Z/V/G

Z/R

AHSB

The bespoke Studio Piet Boon, based in Amsterdam, managed to create a tailor-made and unique interior design able to grasp the inner essence of the Strandhotel in Cadzand. Their concept approach blends exterior, interior and styling with each project's context, culture and environment delivering outstanding quality and ensuring an excellent experience of stay.

AHSB220 are positioned at the entrance, in combination with **AUS130**.



AK

	a	b	h	w	m ³
AK40	47cm	23cm	40cm	20kg	27,5l
AK50	56cm	25cm	49cm	30kg	52l
AK60	70cm	35cm	60cm	40kg	108,5l
AK70	75cm	40cm	70cm	55kg	150,5l
AK80	88cm	48cm	81cm	70kg	246,1l
AK90	99cm	53cm	91cm	100kg	398,9l
AK100	110cm	58cm	101cm	135kg	526l
AK110	120cm	62cm	110cm	180kg	704l
AK120	130cm	70cm	120cm	200kg	880l

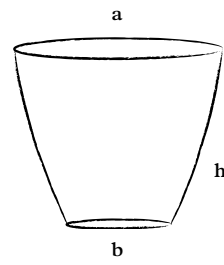

AK40	18,5"	9"	15,7"	45lbs	7,3gal
AK50	22"	9,8"	19,3"	65lbs	13,7gal
AK60	27,5"	13,8"	23,6"	90lbs	28,7gal
AK70	29,5"	15,7"	27,5"	120lbs	39,8gal
AK80	34,6"	18,9"	31,9"	155lbs	65gal
AK90	39"	20,9"	35,8"	220lbs	105,4gal
AK100	43,3"	22,8"	39,8"	297lbs	139gal
AK110	47,2"	24,4"	43,3"	396lbs	186gal
AK120	51,2"	27,6"	47,2"	440lbs	232,4gal



AK60 - G/WW/G

AK60 - W/WW/G



Designed by Philippe Allaey, the **ALPH bench** consists of volumes in clay and a wooden Iroko top structure. Available in different colours and finishes, the bench promotes itself for its variety, flexibility in lay out and endless combinations, fitting in different architectural contexts.

Custom sizes and length on demand.

ALPH-BENCH



ALPH-BENCH



Clay
colours,
textures
& finishes

A unique combination of different textures & shapes

— Texture can make or break a structure or building; it is a crucial part of architecture and it has long been used by architects to breathe life into buildings as well as to create a unique experience for occupant's senses, creating pattern or rhythm and allowing the viewer to believe the piece moves through space. In this perspective, textures create a different experience: they allow more than one sense to be used at once by just "seeing" it and ensure the viewer a full sensorial experience. Atelier Vierkant provides costumers with a vast array of 16 different textures that can be used and applied to structures, objects, shapes and forms, as well as mixed and matched with our colour palette.

— Expressing the true quality of materials and shaping an interior space or simply articulating a pattern, texture gives structure and strength to the object. On a finer level of detail, the texture is, in fact, the skin of the pot and the true expression of its meaning as well as of its character. It gives beauty to the shape and emphasizes volumes and plays of natural light on the surface of the vases. The combination between the natural pattern of the clay and the texture chosen creates a unique piece that is linked with the context and with the elements of the surrounding environment in a strong and indissoluble way. The designer's choice is a vast selection of possibilities to combine a model with one of the many available textures, which are indicated in a practical table with a numeric symbol. The reader will find for each model the recommended textures available, and samples of the specific texture can be sent upon request.

Clay Perfumes

— Besides the 9 clay body colours, Atelier Vierkant last year launched 27 new engobe top colours –clay perfumes– which can be applied on the outside of the natural clay.

— Engobe, a liquid clay slip applied on the outside of the ceramic body, is mixed with oxides and fired upon the surface of the pot. The 27 fragrances are used as accents that embellish the shapes and volumes. They often cover partly the model, from time to time entirely, but in most cases their favour mixes with the body of the clay on which they are applied. Engobe applications are done on demand and patterns are customized to order.

— Clay colours and textures can be mixed together, resulting in the widest display of possible choices and combinations and matching each client's expectations in the most personal and unique way.

Clay body Colours

The highly chamotted clay Atelier Vierkant works with is naturally coloured in the mass by oxides and pigments in 9 different shades: Atelier Vierkant's body colours. During the firing process, those oxides are absorbed by the clay body so that they do not fade away with external weather agents – UV rays, rain, heat, frost. Samples of body colours can be sent upon request.

Colours, textures & surfaces

Colours

Atelier Vierkant offers a range of nine clay bodies, coloured in the mass with natural oxides. Chromatic consistency, durability and resistance to continuous exposure to uv rays, humidity and frost, make our products a lifetime experience of pleasure. Samples of the clay colours & textures can be sent upon request.



Surface colours

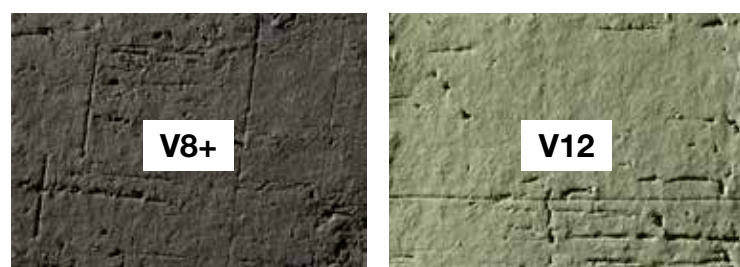
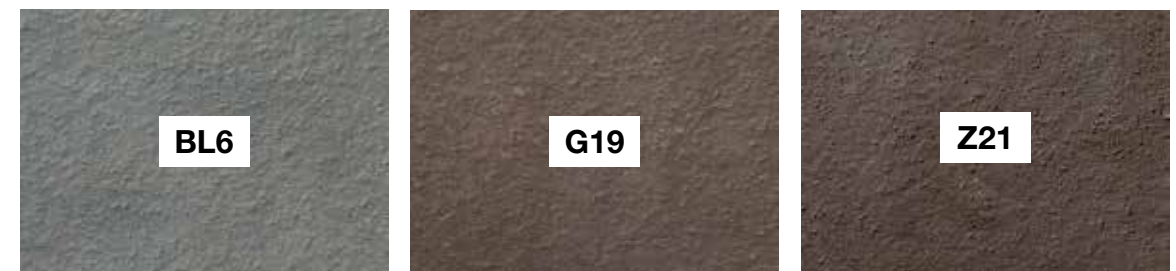
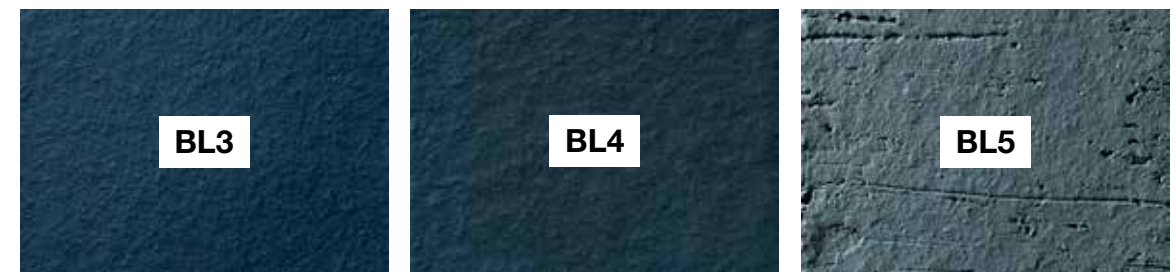
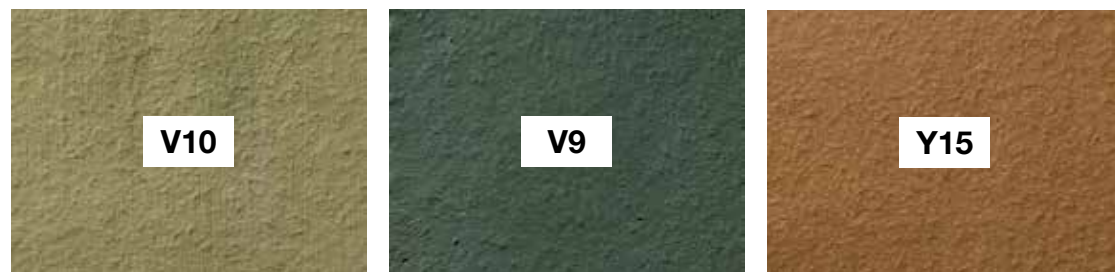

Besides the 9 clay body colours, Atelier Vierkant launched 27 new engobe top colours – clay perfumes – which can be applied on the outside of the natural clay.

Textures

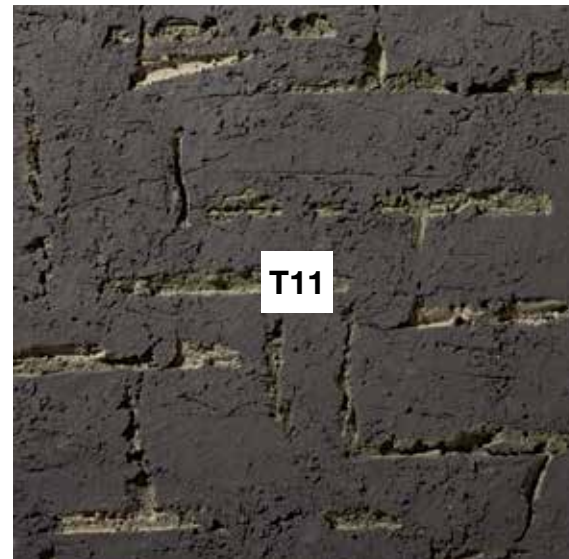
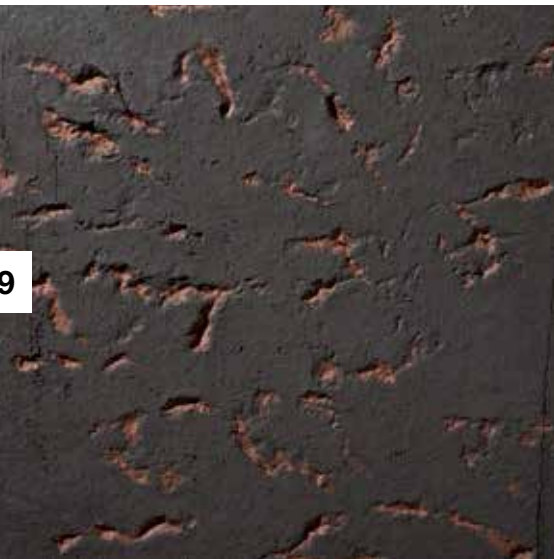
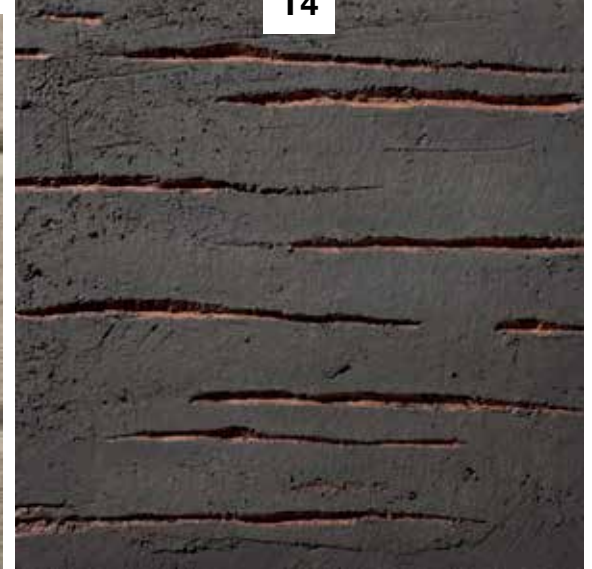
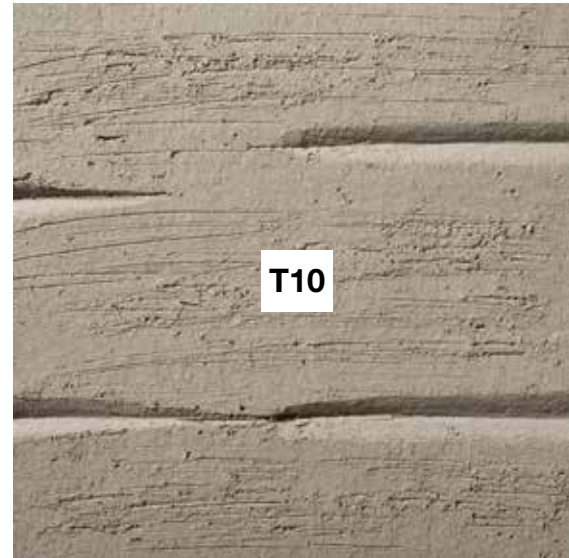
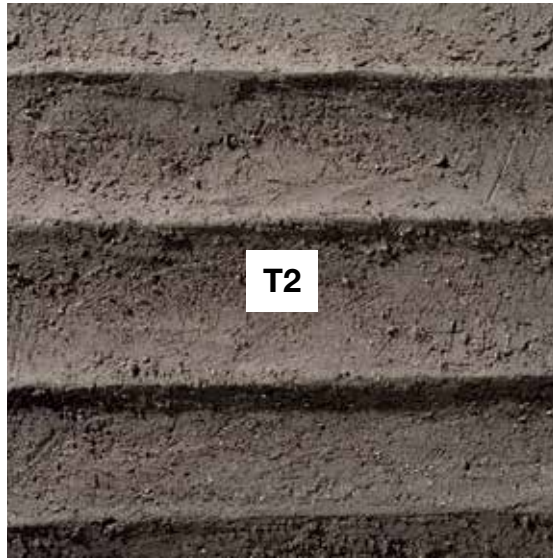
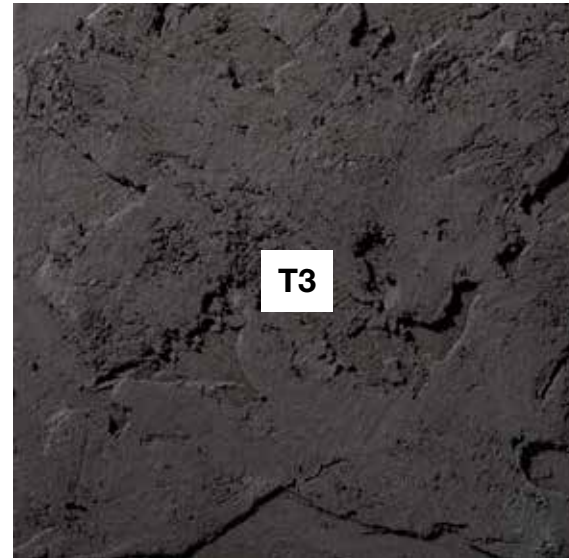

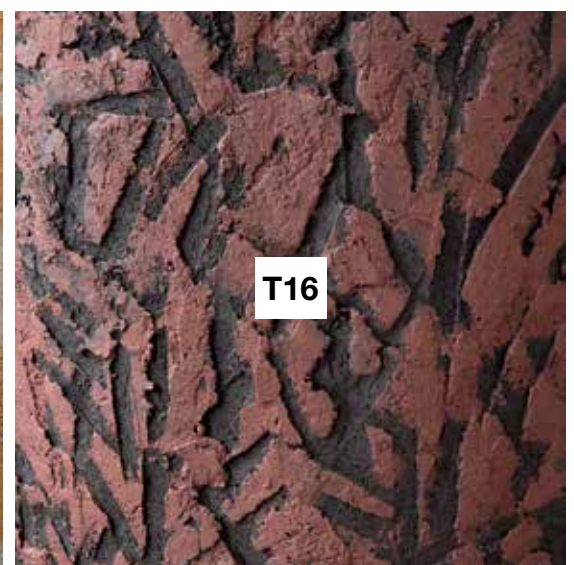
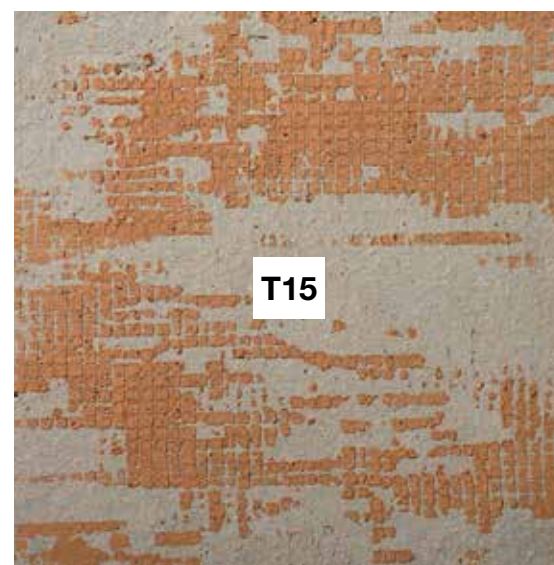
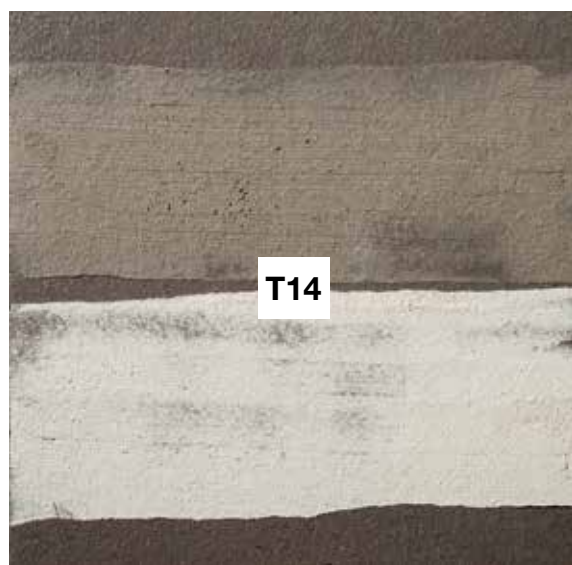
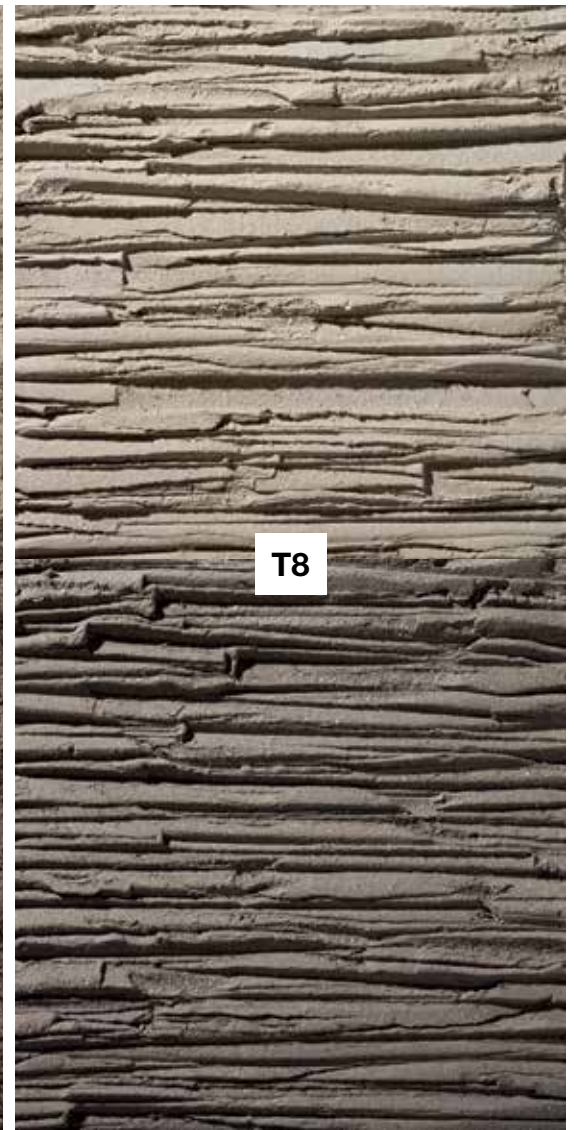
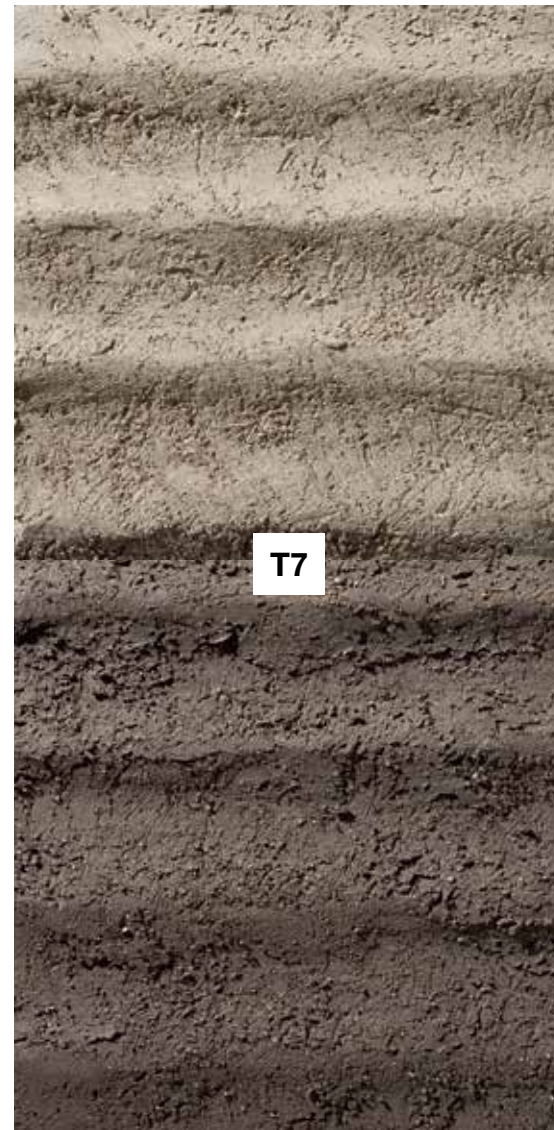
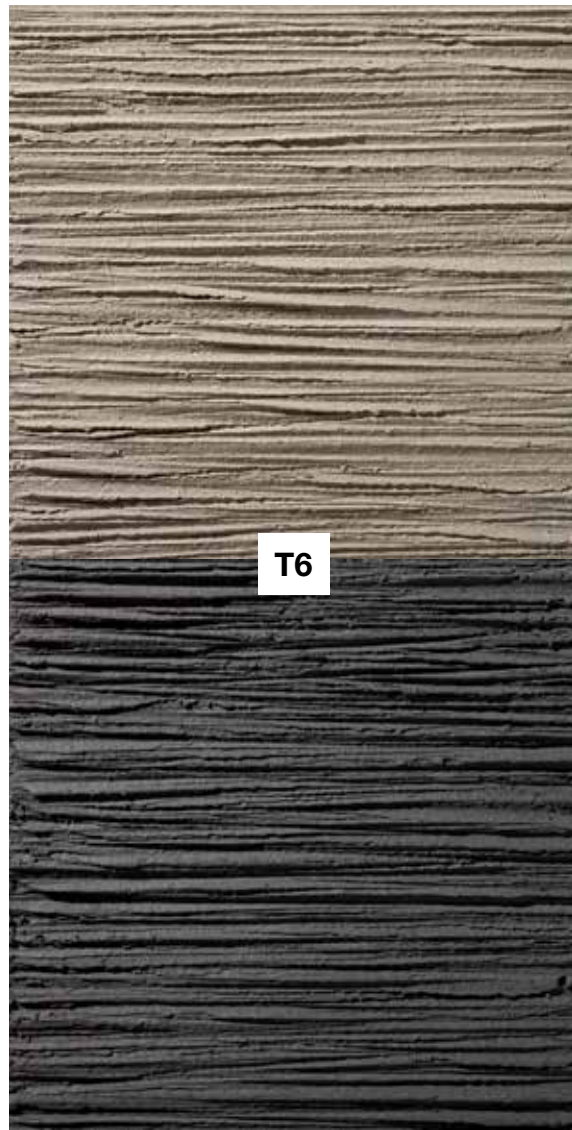
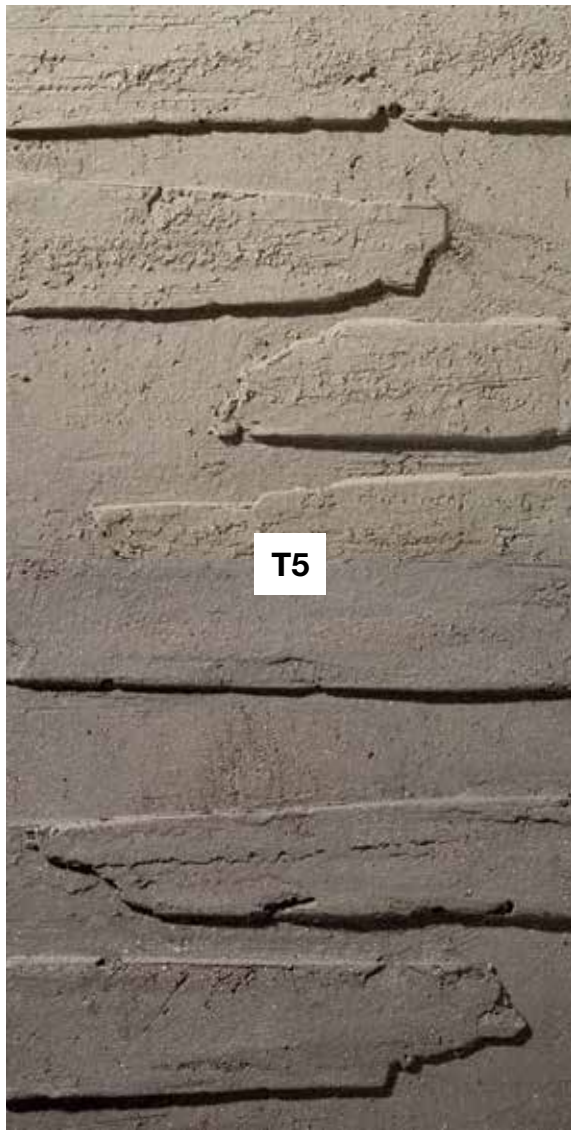



ALPH1



ALPH2



ALPH3



ALPH4



ALPH5



ALPH6



ALPH7



ALPH8



ALPH9



ALPH10



ALPH11



ALPH12



ALPH13



ALPH14



ALPH15



ALPH16



ALPH17



ALPH18



ALPH19



ALPH20



ALPH21



ALPH22



ALPH23

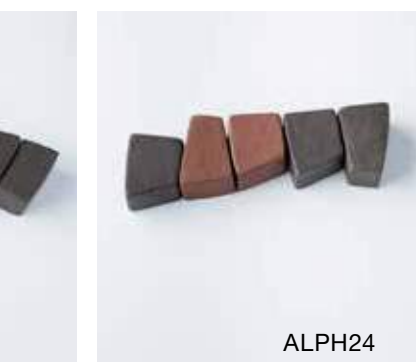

ALPH24

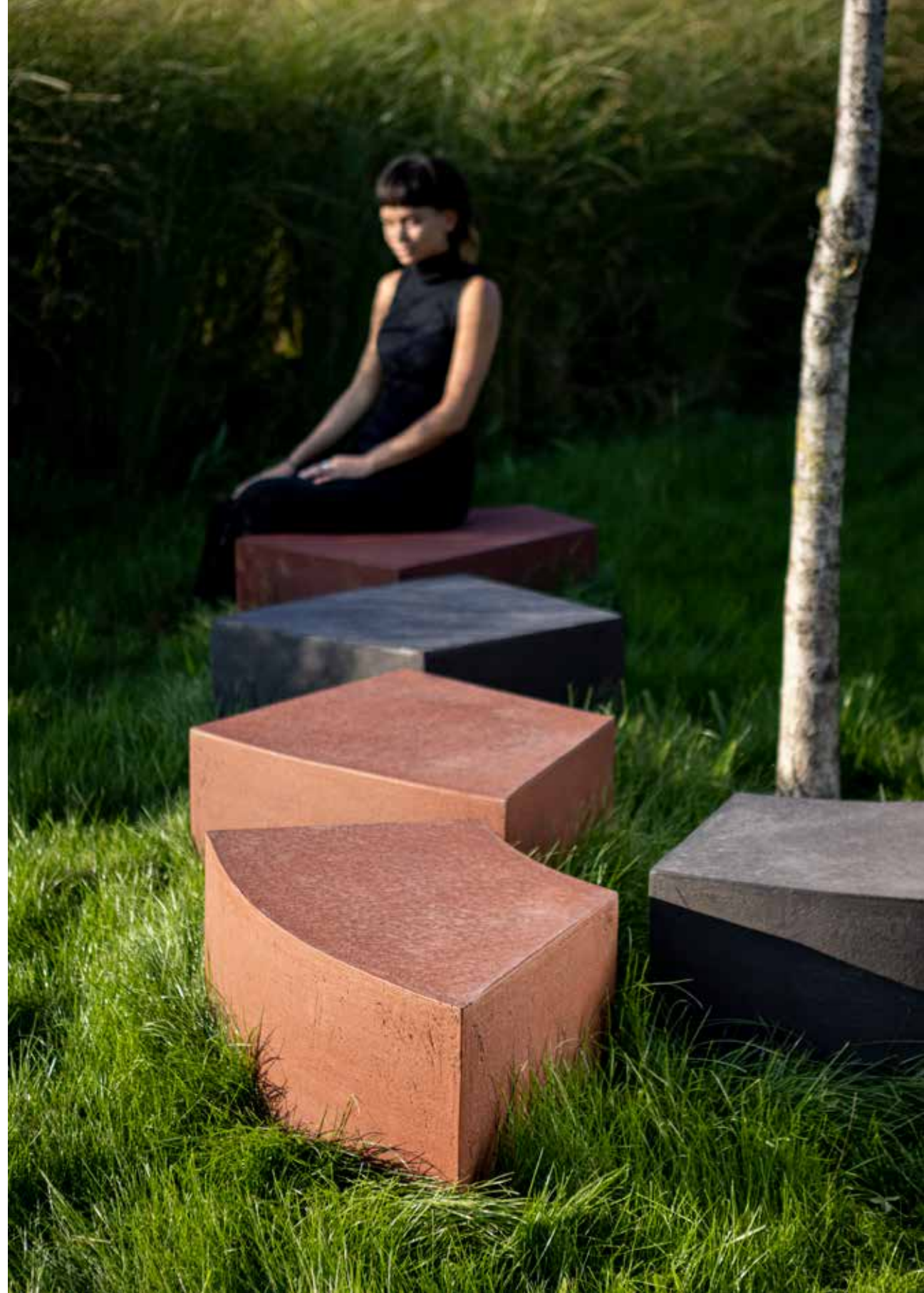

AS

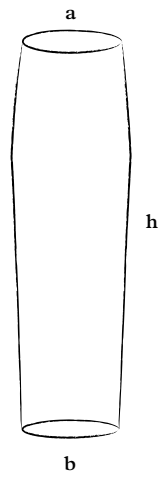

	a	b	h	w
AS60 (Felix)	48cm	48cm	60cm	60kg
AS70 (Gigi)	60cm	60cm	70cm	60kg
AS130 (Irma)	50cm	50cm	126cm	80kg
AS150 (Cloë)	37cm	37cm	153cm	95kg
AS160 (Elio)	58cm	58cm	160cm	130kg
AS170 (Denise)	40cm	40cm	171cm	130kg
ASD170 (Henri)	45cm	45cm	171cm	130kg
AS60 (Felix)	18,9"	18,9"	23,6"	132lbs
AS70 (Gigi)	23,6"	23,6"	27,6"	132lbs
AS130 (Irma)	19,7"	19,7"	49,6"	176lbs
AS150 (Cloë)	14,6"	14,6"	60,2"	209lbs
AS160 (Elio)	22,8"	22,8"	63"	286lbs
AS170 (Denise)	15,7"	15,7"	67,3"	286lbs
ASD170 (Henri)	17,7"	17,7"	67,3"	286lbs

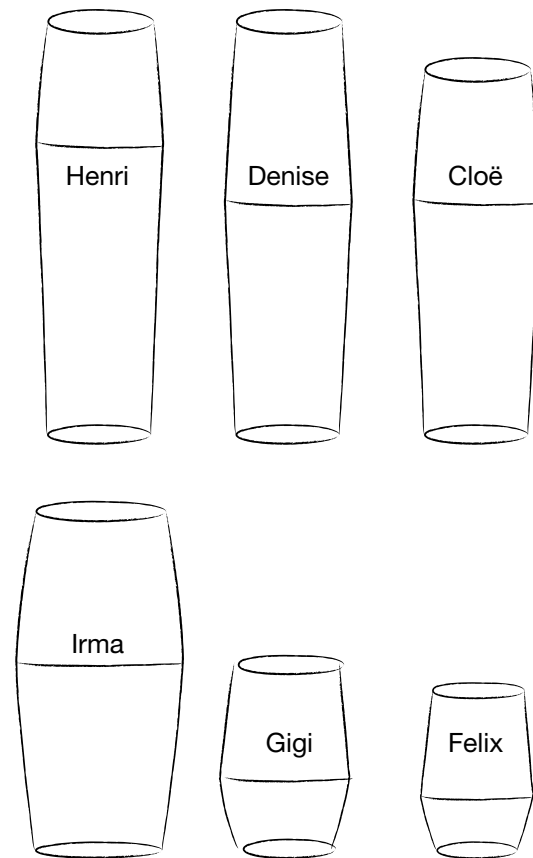



CHLOE
WW/G20

ELIO
WW/11

HENRI
WS/V11

DENISE
WS/BL6

CHLOE
W/G20

CHLOE
W/G20

CHLOE
Z/V8

DENISE
Z/BR24

IRMA
W/G20

ASL

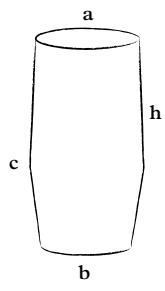

	a	b	c	h	w
ASL	39cm	31cm	41cm	72,5cm	40kg
ASL	15,4"	12,2"	16,1"	28,5"	88lbs



OPTION 1 / W



OPTION 2 / W



OPTION 3 / WW



OPTION 4 / W



OPTION 5 / WW



AU

	a	b	h	w	m ³
AU60	54cm	28cm	60cm	35kg	60l
AU70	63cm	33cm	70cm	50kg	120l
AU80	72cm	37cm	80cm	65kg	180l
AU100	90cm	45cm	100cm	150kg	380l
AU130	120cm	65cm	130cm	200kg	958l
AU180	165cm	85cm	180cm	650kg	2885l
AU60	21,3"	11"	23,6"	77,2lbs	15,8gal
AU70	24,8"	13"	27,6"	110lbs	31,7gal
AU80	28,3"	14,6"	31,5"	143,3lbs	47,5gal
AU100	35,4"	17,7"	39,3"	330lbs	100,3gal
AU130	47,2"	35,5"	51,1"	440lbs	253gal
AU180	64,9"	33,4"	70,8"	1430lbs	762,1gal

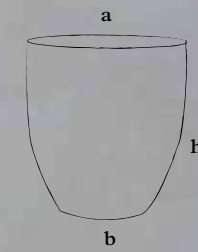

AUB

	a	b	h	w	m3
AUB60	54cm	28cm	60cm	40kg	60l
AUB70	63cm	33cm	70cm	60kg	120l
AUB80	72cm	37cm	80cm	85kg	180l
AUB100	90cm	45cm	100cm	150kg	380l
AUB130	120cm	65cm	130cm	250kg	958,3l

AUB60	21,3"	11"	23,6"	88lbs	15,8gal
AUB70	24,8"	13"	27,6"	132lbs	31,7gal
AUB80	28,3"	14,6"	31,5"	187lbs	47,6gal
AUB100	35,4"	17,7"	39,3"	330lbs	100,4gal
AUB130	47,2"	25,5"	51,1"	550lbs	253,2gal

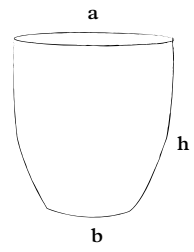

As soon as clients approach Corales Suites in Adeje, Tenerife, they are captivated by the sinuous curves of its massive white contemporary-style building. White models from the **AUB** series are used to guide clients and staff along the wooden pavement of one of the many outdoor passages, breaking the horizontal lines of the grey walls and adding volume through use of texture and the bright white colour. The sense of verticality is created by the upwards motion of *Hyophorbe lagenicaulis*.

AUB



AUB130 in front of restaurant
The Jane, Antwerp



AUB180

	a	b	h	w
AUB180	165cm	85cm	180cm	800kg
<i>AUB180</i>	64,9"	33,4"	70,8"	1763lbs

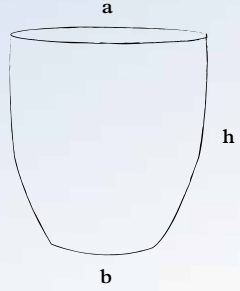

AUI

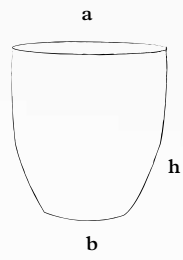

	a	b	h	w	m ³
AUI80	72cm	37cm	80cm	85kg	180l
AUI100	90cm	45cm	100cm	150kg	380l
AUI130	120cm	65cm	130cm	250kg	958,3l
AUI80	28,3"	14,6"	31,5"	187lbs	47,6gal
AUI100	35,4"	17,7"	39,4"	330lbs	100,4gal
AUI130	47,2"	25,6"	51,2"	550lbs	253,2gal



AUO

	a	b	h	w	m ³
AUO80	72cm	37cm	80cm	65kg	180l
AUO100	90cm	45cm	100cm	150kg	380l
AUO130	120cm	65cm	130cm	250kg	958,3l

AUO80	28,3"	14,6"	31,5"	143,3lbs	47,6gal
AUO100	35,4"	17,7"	39,4"	330lbs	100,4gal
AUO130	47,2"	25,6"	51,1"	550lbs	253,2gal

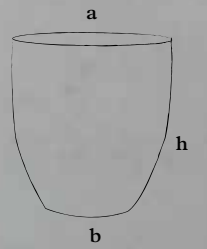

AUO Series characterized by their honeycomb texture, developed and designed in dialogue with Dutch architect Osiris Hertman, is available in 3 sizes: 80, 100 and 130 height.



AUO100

AUS

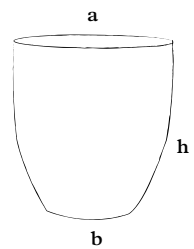

	a	b	h	w	m ³
AUX80	56cm	27cm	80cm	45kg	120l
AUSX80	56cm	27cm	80cm	45kg	120l
AUS80	72cm	37cm	80cm	65kg	180l
AUS100	90cm	45cm	100cm	150kg	380l
AUX80	22"	10,6"	31,5"	99,2lbs	31,7gal
AUSX80	22"	10,6"	31,5"	99,2lbs	31,7gal
AUS80	28,3"	14,6"	31,5"	143,3lbs	47,6gal
AUS100	35,4"	17,7"	39,3"	330lbs	100,4gal



AUS100

Located on the South Coast of the Lake of Zürich, Mönchhof Restaurant offers wide views in combination with excellent local Swiss cuisine. Landscape architect Jack Richard was asked to arrange a planting scheme for the entry and pathway that welcomes guests. He therefore selected a series of **AUS100** in grey with white accents.

G/W22

AUS80R/W22





AUS180

	a	b	h	w
AUS180	165cm	85cm	180cm	800kg
<i>AUS180</i>	64,9"	33,4"	70,8"	1763lbs

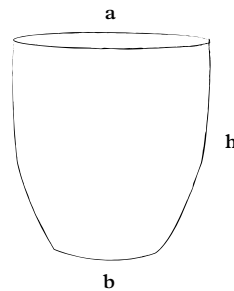

B

	a	c	h	w	m ³	
B2080	20cm	20cm	80cm	20kg	16l	
B20100	20cm	20cm	100cm	25kg	21l	
B20120	20cm	20cm	120cm	30kg	25l	
B3060	28cm	28cm	55cm	25kg	24l	
B3080*	30cm	30cm	80cm	35kg	34l	
B30100*	30cm	30cm	100cm	40kg	57l	
B30120*	30cm	30cm	120cm	50kg	69l	
B2080	7,9"	7,9"	31,5"	45lbs	4,2gal	
B20100	7,9"	7,9"	39,4"	55lbs	5,5gal	
B20120	7,9"	7,9"	47,2"	65lbs	6,6gal	
B3060	11"	11"	21,6"	55lbs	6,3gal	
B3080*	11,8"	11,8"	31,5"	77lbs	9gal	
B30100*	11,8"	11,8"	39,4"	88lbs	15gal	
B30120*	11,8"	11,8"	47,2"	110lbs	18,2gal	

* Suitable
for a polyester
innerliner.

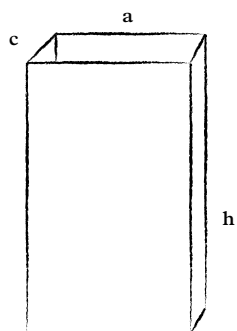

B

	a	c	h	w	m ³
B4060*	40cm	40cm	60cm	35kg	37l
B4080*	40cm	40cm	80cm	45kg	86l
B40100*	40cm	40cm	100cm	55kg	111l
B40120*	40cm	40cm	120cm	65kg	135l
B45100	45cm	45cm	100cm	62kg	145l
B5060*	50cm	50cm	60cm	50kg	102l
B5080*	50cm	50cm	80cm	60kg	142l
B50100*	50cm	50cm	100cm	70kg	183l
B50120*	50cm	50cm	120cm	80kg	223l
B50140*	50cm	50cm	140cm	90kg	264l
B4060*	15,7"	15,7"	23,6"	77lbs	9,8gal
B4080*	15"	15"	31,5"	100lbs	22,7gal
B40100*	15"	15"	39,4"	120lbs	29,3gal
B40120*	15,7"	15,7"	47,2"	145lbs	35,7gal
B45100	17,7"	17,7"	39,4"	137lbs	38,3gal
B5060*	18,9"	18,9"	23,6"	110lbs	26,9gal
B5080*	18,9"	18,9"	31,5"	130lbs	37,5gal
B50100*	19,7"	19,7"	39,4"	155lbs	48,3gal
B50120*	19,7"	19,7"	47,2"	175lbs	58,9gal
B50140*	19,7"	19,7"	55,1"	200lbs	69,7gal

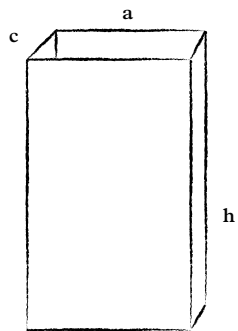



B

B50100 black
SOFAZ tower, Baku

B-CUBE

Custom sizes available

* Suitable for a polyester innerliner.



	a	h	w	m ³
B3030	30cm	30cm	15kg	19l
B4040	40cm	40cm	20kg	37l
B5050*	50cm	50cm	50kg	81l
B6060	60cm	60cm	70kg	152l
B6565	65cm	65cm	78kg	198l
B7070	70cm	70cm	85kg	254l
B8060	80cm	60cm	85kg	282l

	a	h	w	m ³
B3030	11,8"	11,8"	35lbs	5gal
B4040	15,7"	15,7"	45lbs	9,8gal
B5050*	19,7"	19,7"	110lbs	21,4gal
B6060	23,6"	23,6"	155lbs	40,2gal
B6565	25,6"	25,6"	173lbs	52,3gal
B7070	27,6"	27,6"	190lbs	67,1gal
B8060	31,5"	23,6"	190lbs	74,5gal

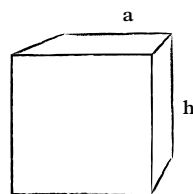

B8060 black planted with kentia palm.
Sofia Hotel, Barcelona



B-CUBE



B5050 grey,
MAS, Belgium

BE4545

OPTION 1 – Black anthracite cube with gold-copper surface engobe colour accent



BE4545

	a	h	w
BE4545	45cm	45cm	40kg
BE4545	17,7"	17,7"	88lbs

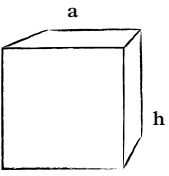

OPTION 2 — Black anthracite cube with white, gold and brown surface engobe pattern

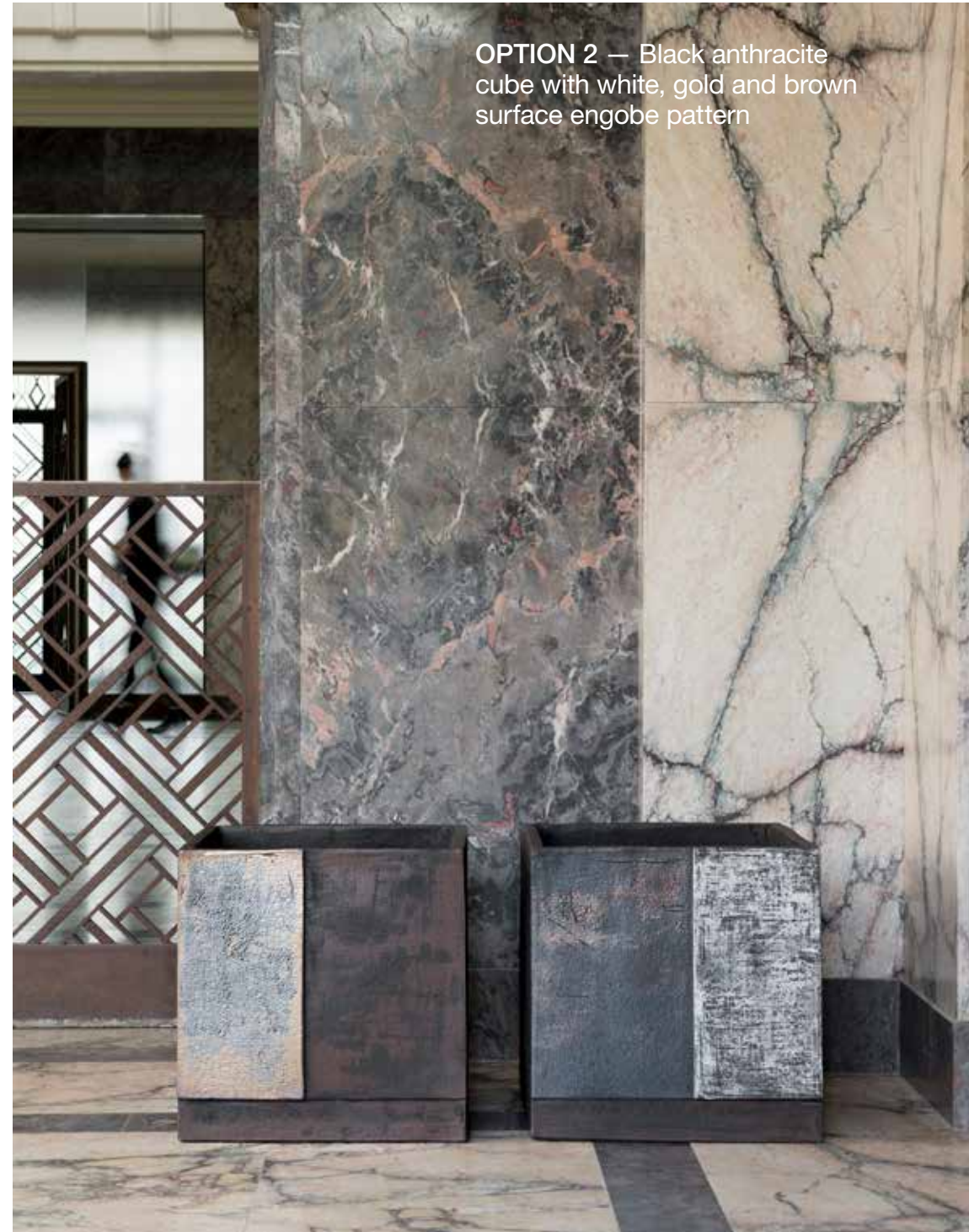

BE4545

OPTION 3 — Black anthracite twin cubes with gold and copper surface colour pattern



BC

	a	b	h	w	m ³
BC40	45cm	50cm	44cm	35kg	75l
BC50	55cm	60cm	53cm	50kg	141l
BC100	87cm	95cm	83cm	125kg	315l
BC40	17,7"	19,7"	17,3"	77lbs	19,8gal
BC50	21,6"	23,6"	20,8"	110lbs	37,2gal
BC100	34,3"	37,4"	32,7"	276lbs	83,2gal

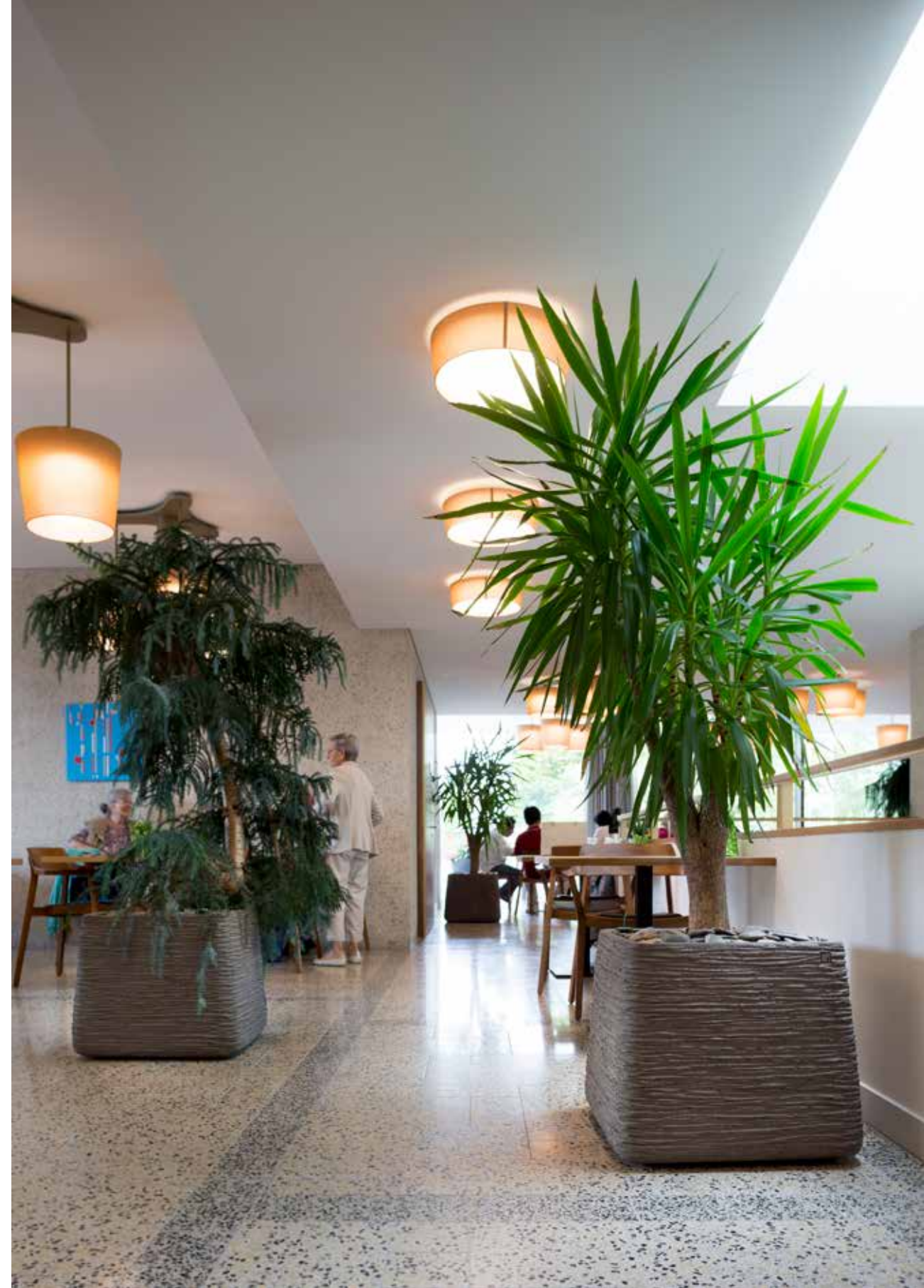
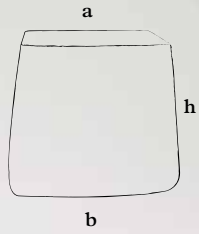



BC50 black and
BCH90 white
Echelon Towers,
Singapore

BCH

	a	b	h	w	m ³
BCH90	55cm	60cm	90cm	75kg	225l
BCH90	21,6"	23,6"	35,4"	165lbs	59,4gal

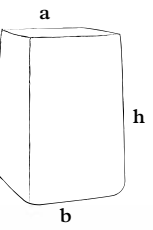

The owners of a holiday home on a Greek island wanted an interior design that did justice to the rough, Mediterranean hills of the island. Wolterinck interpreted this into a design with pure and raw materials, rich in texture and earthy tints. The house itself, built 25 years ago as a third holiday home on the island, leant this way too, with its sober, uneven floors and rough natural stone walls.

Wolterinck introduced furniture made from untreated wood, dark rugs and pieces of art whose shapes, patterns and colours appear wild and picturesque. The lie of the house in the shelter of the rocky slope, looking out of the infinite azure blue sea enticed Wolterinck to make grand gestures: ceramic planters, robust lamps and spacious seating on the patio with austere steel mirrors on the walls. The reflections of the sky and the sea give colour, the cool outside light stands out against the dark grey stones.



BCH

BCH150

	a	b	h	w
BCH150	45cm	50cm	150cm	100kg
BCH150	17,7"	19,6"	59"	220lbs

Possibility to have personalized engraving.

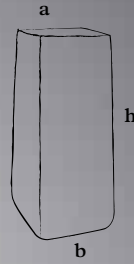

BG

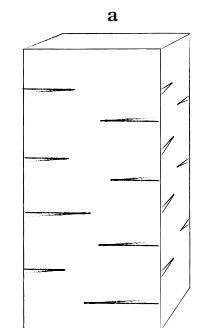

	a	h	w	m ³
BG5050	50cm	50cm	50kg	81l
BG40120*	40cm	120cm	75kg	135l
BG5050	19,7"	19,7"	110lbs	21,4gal
BG40120*	15,7"	47,2"	165lbs	35,7gal

* Suitable for a polyester innerliner.

BL

*With a total length of over 1,8m,
the BL model is available as a
total installation, as well as in
individual parts.*

More detailed info on request.

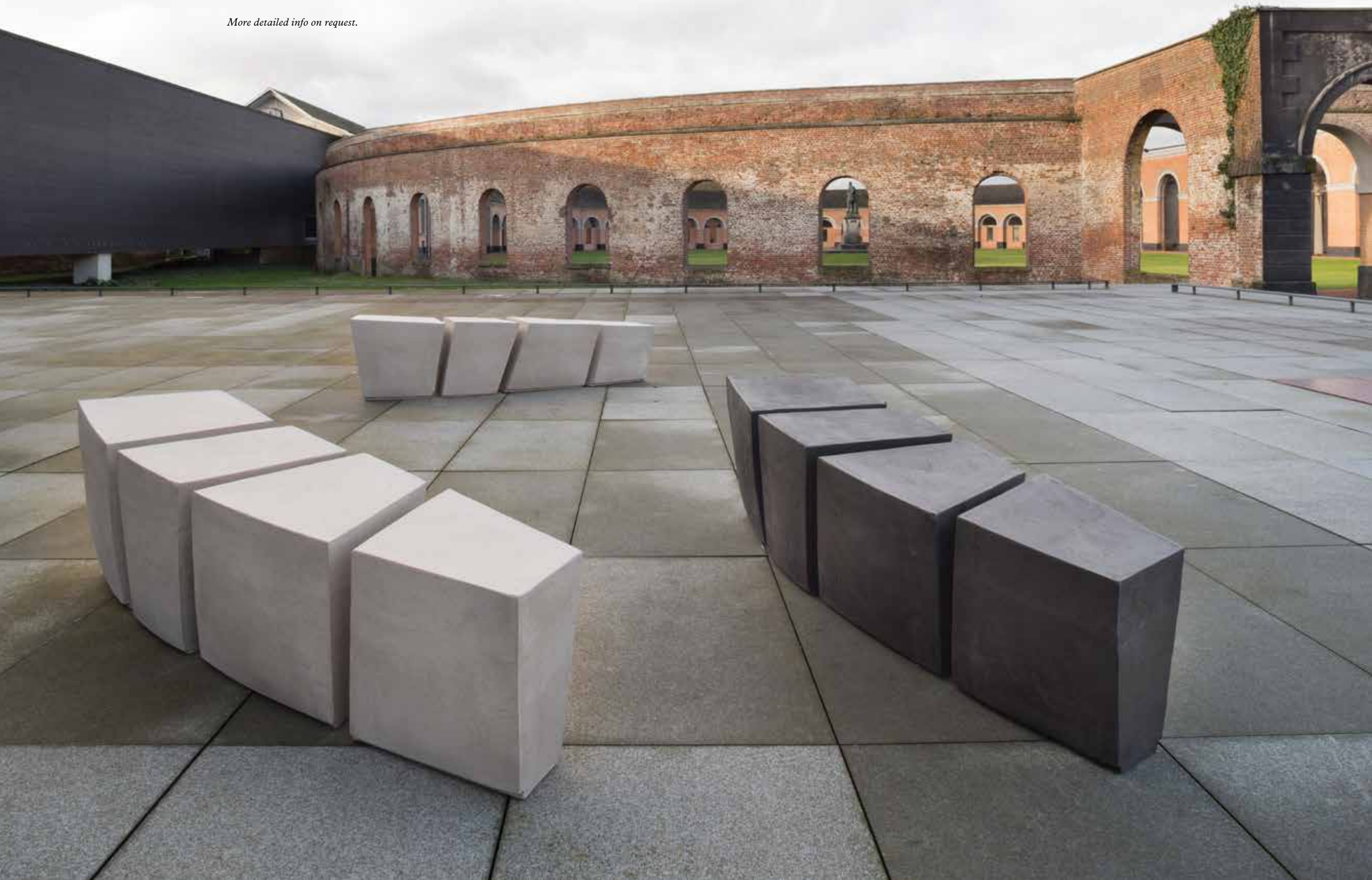

Decidedly global in its outlook, the modern metropolis of Singapore has kept a foot firmly rooted in tradition. Today quaint colonial-era shophouses sit alongside shimmering skyscrapers; temples, mosques and churches share the same streets; and open-air food courts sell tasty and authentic fare just footsteps from fine dining establishments. Singapore continues to defy expectations.

The Link Bridge Gallery, between Four Seasons and Hilton Hotel, offers room for temporary art installations. In this setting, the **BL180** is presented with lush green at the background.

BL





For the decoration for the historic Piazza delle Erbe at Riva del Garda, Frizzi Giardinieri selected the **BL** bench in white beige finish with centered **O90** planted with *Pittosporum*.



BM

	a	h	w	m ³
BM5050	50cm	50cm	45kg	81l
BM40120*	40cm	120cm	60kg	135l
BM50100*	50cm	100cm	65kg	185l
BM5050	19,7"	19,7"	100lbs	21,4gal
BM40120*	15,7"	47,2"	130lbs	35,7gal
BM50100*	19,7"	39,4"	145lbs	48,9gal

*Suitable for a polyester innerliner.

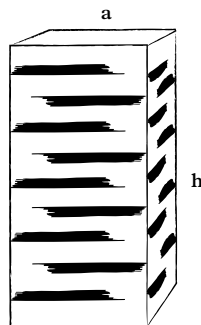

BRF

	a	c	h	w	m ³
BRF100	50cm	35cm	100cm	100kg	122l
BRF120	50cm	35cm	120cm	115kg	150l
BRF100	19,7"	13,8"	39,4"	220lbs	32,2gal
BRF120	19,7"	13,8"	47,2"	255lbs	39,6gal





BRF120 grey
River Grill, Hamburg.

BS

	a	b	h	c	w	m ³
BS40	40cm	40cm	50cm	40cm	30kg	49l
BS50	50cm	50cm	60cm	50cm	45kg	102l
BS75	50cm	50cm	75cm	50cm	60kg	132l
BS40	15,7"	15,7"	19,6"	15,7"	65lbs	12,9gal
BS50	19,6"	19,6"	23,6"	19,6"	100lbs	26,9gal
BS75	19,6"	19,6"	29,5"	19,6"	132lbs	34,9gal

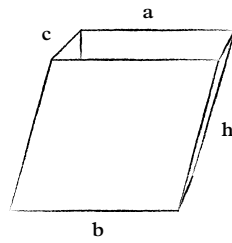

BS is a square vase.



Customized
rectangular **BS**
in black
anthracite finish

BP

	a	h	w	m ³
BP60	60cm	60cm	60kg	152l
BP60	23,6"	23,6"	135lbs	40,2gal

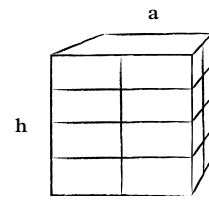

BR

	a	c	h	w	m ³
BR55	45cm	25cm	55cm	30kg	36l
BR80*	50cm	30cm	80cm	50kg	80l
BR100*	50cm	30cm	100cm	60kg	102l
BR120*	50cm	30cm	120cm	70kg	124l
BR55	17,2"	9,8"	21,6"	65lbs	9,5gal
BR80*	19,7"	11,8"	31,5"	110lbs	21,1gal
BR100*	19,7"	11,8"	39,4"	135lbs	26,9gal
BR120*	19,7"	11,8"	47,2"	155lbs	32,8gal

* Suitable for a polyester innerliner.

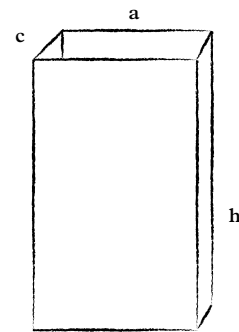



BRL10060 white
Klésia, Paris

BRL

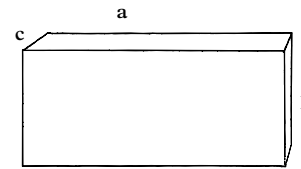

	a	c	h	w	m ³
BRL6040	60cm	30cm	40cm	40kg	42l
BRL6060	60cm	30cm	60cm	45kg	69l
BRL6080	60cm	30cm	80cm	55kg	97l
BRL8040	80cm	30cm	40cm	50kg	57l
BRL8060	80cm	30cm	60cm	75kg	94l
BRL8080	80cm	30cm	80cm	85kg	132l
BRL10040	100cm	30cm	40cm	65kg	72l
BRL10060	100cm	30cm	60cm	85kg	109l
BRL10080	100cm	30cm	80cm	105kg	167l
BRL6040	23,6"	11,8"	15,7"	90lbs	11gal
BRL6060	23,6"	11,8"	23,6"	100lbs	18,2gal
BRL6080	23,6"	11,8"	31,5"	120lbs	25,6gal
BRL8040	31,5"	11,8"	15,7"	110lbs	15gal
BRL8060	31,5"	11,8"	23,6"	165lbs	24,8gal
BRL8080	31,5"	11,8"	31,5"	185lbs	34,9gal
BRL10040	39,4"	11,8"	15,7"	145lbs	19gal
BRL10060	39,4"	11,8"	23,6"	190lbs	28,8gal
BRL10080	39,4"	11,8"	31,5"	230lbs	44,1gal

*Customized sizes
are possible.
Info upon request.*



BRL



BRL8060 extra white
Malibu, CA

Relics Damien Hirst

BTV

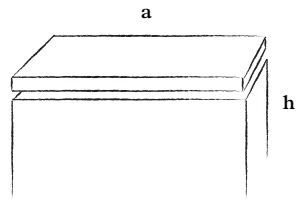

*BTV includes
pedestal and plate.*

	a	h	w
BTV3080	30cm	85cm	40kg
BTV30100	30cm	105cm	45kg
BTV4080	40cm	85cm	50kg
BTV40100	40cm	105cm	60kg
BTV40120	40cm	125cm	80kg
BTV5080	50cm	85cm	75kg
BTV50100	50cm	105cm	100kg
BTV50120	50cm	125cm	120kg
BTV50140	50cm	145cm	130kg

<i>BTV3080</i>	<i>11,8"</i>	<i>33,4"</i>	<i>88lbs</i>
<i>BTV30100</i>	<i>11,8"</i>	<i>41,3"</i>	<i>100lbs</i>
<i>BTV4080</i>	<i>15,7"</i>	<i>33,4"</i>	<i>110lbs</i>
<i>BTV40100</i>	<i>15,7"</i>	<i>41,3"</i>	<i>135lbs</i>
<i>BTV40120</i>	<i>15,7"</i>	<i>49,2"</i>	<i>175lbs</i>
<i>BTV5080</i>	<i>19,7"</i>	<i>33,4"</i>	<i>165lbs</i>
<i>BTV50100</i>	<i>19,7"</i>	<i>41,3"</i>	<i>220lbs</i>
<i>BTV50120</i>	<i>19,7"</i>	<i>49,2"</i>	<i>265lbs</i>
<i>BTV50140</i>	<i>19,7"</i>	<i>57,1"</i>	<i>285lbs</i>

Clay Labora- tories



*“Designed,
developed and
manufactured
in Belgium:
the product cycle
kept within the
boundaries of
one workshop.”*

Clay Laboratories





— Atelier Vierkant promotes clay to design. They do that in their own unique way without compromise: headstrong, as becomes the Belgians. The handcrafted creations are conquering the world and can be admired in the most exclusive locations. Belgium may be one of the smallest European countries, but despite its modest size, the innovation of its many artistic talents cannot be confined. From fashion to interior designers to top chefs, each and every one understands the art of combining design and terroir, and the results are praised the world round. Belgium has proven itself a design force to be reckoned with at the international level. ‘Made in Belgium’ has evolved into a quality label like no other. Atelier Vierkant does it with clay: clay coming from Western Europe that is transformed into unique handcrafted pots in their Belgian studio, 70 tonnes per week. How does one give clay, a centuries-old material, its own contemporary design personality? There are no standard objects here, only authentic designs of artisanal quality, design pieces with a heart and soul: made by hand, slowly and meticulously. Sleek, but never cold. Two pieces are never exactly alike. Each design that leaves the premises is entirely unique and bears the stamp of its creator.

Clay Laboratories



— Willy and Annette Janssens, the founders and designers of Atelier Vierkant, are endlessly at work in their studio, their hands immersed in clay, rooting and wrestling with this material. It is here that all their creations are born, destined to seize the world by adorning its most beautiful places: from luxurious villas to grand city hotels to exotic gardens. «Clay is our foundation and it is with that material that we begin our journey. We think with our hands and the rest follows.» In so doing Atelier Vierkant is continuously stretching its technical boundaries in order to reach results that hardly seem possible. «The clay consumes us, yet it is we who control it.» It is in that field of tension that exquisite, functional objects come to life: layered, organic and distilled. A robust and proud presence, but never shrill. Architectural, functional elements and artistic sculptures at the same time.

Clay Laboratories



— Even though the design is born in Belgium, the whole world is home for Atelier Vierkant products. The constant strive to create a context where people can connect with natural materials and benefit from a more familiar and not impersonal environment is the reason why Atelier Vierkant pots can be found in the most exclusive locations around the world, creating cohesion and continuity with the surrounding environment and ensuring a superior aesthetic experience. Just as unconventional as their monumental pots, so too is Atelier Vierkant's way of working: no agent, no importer, no adverts. Because what you do yourself, you always do better. Willy and Annette are responsible for the designing of the objects and their three sons do the rest. It's an intensive way to work, but it is the only option. «This is the foundation of who we are».

No impersonal offices hermetically sealed from the work floor, but rather an impressive and lively studio that is the true beating heart of this passionate family business. Atelier Vierkant has a worldwide network of 3,000 architects and designers with whom it closely collaborates creating ad hoc, unique projects. Each collaboration is unique in itself and lead to always unexpected, surprising results: exclusive restaurants in France, luxury Hotels in Barcelona, amazing private houses in New Zealand and much more. We have built strong relationships based on trust with each of these partners. Any calls or queries are answered personally: no expensive, delaying and unnecessary in-between steps, instead just a direct, intensive and close collaboration. «We don't want any middlemen, no adverts. The price is determined by the product and the product only. We want our clients to be happy and stay happy, and that's only possible if you have control of everything yourself. We're always close by».

Clay Laboratories



We feel and breathe our profession which boasts on years of collected and collective knowledge. Therefore, Atelier Vierkant functions as a laboratory, a creative think tank and a production hall where the creative process is always on its way to produce something new and never seen before. We are above all partners; together we brainstorm, we research and carry out the entire project from scratches. It's a matter of matching our objects perfectly with the project they are designed for, both in shape and texture. It's an intense process with continuous communication via Skype, sending samples, pictures and even 3D-printed models. «The kilometres that separate us are inconsequential. We're always close by, whether our client lives and works in Dubai, Singapore or Los Angeles. If an architect or designer rings us, we can let them know right then and there that their pots are just being rolled into the oven. That creates trust.»





Clay Laboratories

At the moment, Atelier Vierkant can count on three fully operative workshops. In fact, a new third plant is fully working and it is now ready to increase the number of pots produced daily and to offer clients even more choice from stock.

— Such expansion is implemented accordingly to the impressive, increasing growth rate that Atelier Vierkant has been experiencing during the last decade. There, a worker stands on the top of a wooden crate, bent over to reach and shape the insides of a mould; another artisan, tool in hand, etches deep ridges onto the surface of a round planter, with hands poured in creamy clay; yet another is busy with rolling out of the oven warm, finished vessels. This is the place where, in fact, clay is transformed from raw material into a finished product with dedication and by hand: clay is pressed, shaped, molded into pots and then fired. Once the clay has adapted



to the shape of the mold, the drying process begins: pots are placed under air-blowing pipes, so that the clay can partially release the water trapped in its particles. This process lasts several days in order to let clay dry and become harder. The pots are now ready to be finished and decorated with engravings and textures by the hands of the artisans working in the atelier, before undergoing the second drying process in apposite drying rooms. After several days in the drying rooms, the pots are fired at 1200°C in special ovens and the clay turns into a permanent shape and cannot be altered anymore. Thanks to the high firing temperatures clay will withstand harsh weather conditions such as frost and heat, becoming suitable both for indoor and outdoor use. The pots are now ready to be packed and shipped worldwide with different means of transport, according to the destination: truck, sea freight or air freight.



— Each passage, every process is made inside the facilities of Atelier Vierkant, without depending on any relocation and offshoring process. This means that the production cycle is literally kept short, as it takes place in one single location, being sustainable and allowing the full traceability of the product. Moreover, this allows people who work in the Atelier to have deep and complete understanding of production and supply chain process, being more aware of the value-adding aspects characterizing our pots.

— Besides the three workshop plants, Atelier Vierkant showroom offers both private and professional clients the opportunity to see, touch and feel the vast array of models Atelier Vierkant boasts on. The different shapes, colours and structures displayed are able to inspire clients and offer new, different perspectives on projects, putting sometimes in question the already existing plans and opening their creative minds to new ideas. This is the right place where to get inspired by the unique aura emanating from natural clay.



Clay Laboratories

BZ

	a	h	w	m ³
BZ4080	40cm	80cm	45kg	85l
BZ40100	40cm	100cm	55kg	110l
BZ40120	40cm	120cm	60kg	135l
BZ5060	50cm	60cm	50kg	101l
BZ5080	50cm	80cm	60kg	141l
BZ50100	50cm	100cm	70kg	182l
BZ50120	50cm	120cm	80kg	223l
BZ50140	50cm	140cm	90kg	263l

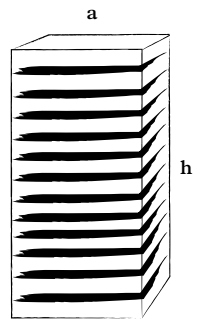

BZ4080	15,7"	31,5"	100lbs	22,4gal
BZ40100	15,7"	39,4"	120lbs	29gal
BZ40120	15,7"	47,2"	130lbs	35,7gal
BZ5060	19,7"	23,6"	110lbs	26,7gal
BZ5080	19,7"	31,5"	130lbs	37,2gal
BZ50100	19,7"	39,4"	155lbs	48,1gal
BZ50120	19,7"	47,2"	175lbs	58,9gal
BZ50140	19,7"	55,1"	200lbs	69,5gal

All BZ models are suitable for a polyester innerliner.





Private residence,
Algarve



CB

	a	h	w
CB50	53cm	41cm	35kg
CB70	72cm	56cm	75kg
CB100	100cm	70cm	150kg
CB50	20,9"	16,1"	77lbs
CB70	28,4"	22"	165lbs
CB100	39,4"	27,6"	330lbs

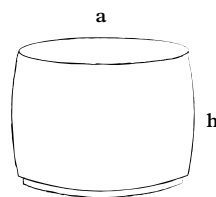

CBH180

	a	h	w
CBH180	55cm	180cm	150kg
CBH180	21,6"	70,8"	330lbs

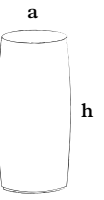



CBH

	a	h	w
CBH80	32cm	80cm	40kg
CBH100	38cm	100cm	65kg
CBH52100	52cm	100cm	65kg
CBH80	13,8"	31,5"	88lbs
CBH100	14,9"	39,4"	143lbs
CBH52100	20,5"	39,4"	143lbs

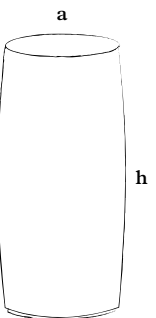



At Relais San Vigilio, landscape architect Katuscia Ratta displayed a series of **CBH100** in grey taupe finish to create different spaces in the breakfast area.

CC50

	a	b	h	w	m ³
CC50	13cm	38cm	52cm	10kg	16,5l
CC50	5,1"	15"	20,5"	22lbs	43,6gal

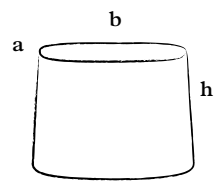



CCL

	a	b	c	d	h	w
CCL50	23,5cm	40cm	27,5cm	47,5cm	54cm	30kg
CCL50	9,1"	15,7"	10,8"	18,7"	22,6"	66lbs

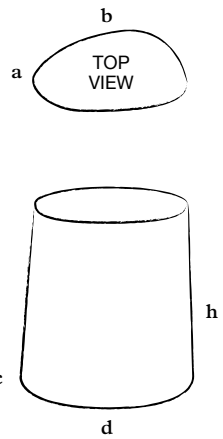

CK80 series
planted with cactus
next to photography
of *Marc Lagrange*

CK80





CK CKB

	a	c	b	h	w
CK60	41cm	30cm	45cm	60cm	30kg
CKB60	41cm	30cm	45cm	60cm	30kg
CK80	56cm	42cm	61cm	82cm	60kg
CKB80	56cm	42cm	61cm	82cm	60kg
<i>CK60</i>	16,1"	11,8"	17,7"	23,6"	66,1lbs
<i>CKB60</i>	16,1"	11,8"	17,7"	23,6"	66,1lbs
<i>CK80</i>	22"	16,5"	24"	32,3"	132,2lbs
<i>CKB80</i>	22"	16,5"	24"	32,3"	132,2lbs

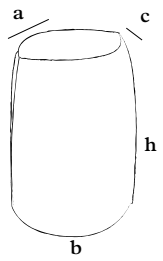

*CK has a standard texture T0
CKB has a rougher texture T1*



CKB80

CKL

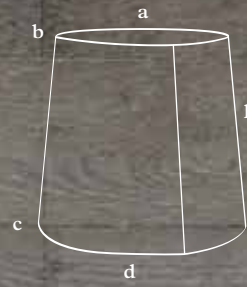

	a	b	c	d	h	w
CKL35	29cm	23cm	36cm	34cm	34cm	15kg
<i>CKL35</i>	11,4"	9"	14,2"	13,4"	13,4"	33lbs



OPTION 1

OPTION 2

OPTION 3



CL

	a	h	w	m ³
CL35	35cm	35cm	20kg	18l
CL40	40cm	40cm	25kg	30l
CL50	50cm	50cm	30kg	66l
CLL50	50cm	21cm	25kg	26l
CL60*	60cm	65cm	50kg	135l
CL70	70cm	70cm	60kg	205l
CL80	80cm	45cm	70kg	158l
CL100	100cm	70cm	110kg	434l
CL35	13,8"	13,8"	44lbs	4,6gal
CL40	15,7"	15,7"	00lbs	7,9gal
CL50	19,7"	19,7"	65lbs	17,4gal
CLL50	19,7"	8,2"	55lbs	6,9gal
CL60*	23,6"	25,6"	110lbs	35,7gal
CL70	27,6"	27,6"	132lbs	54,2gal
CL80	31,5"	17,7"	155lbs	41,7gal
CL100	39,4"	27,6"	242lbs	114,7gal

* Suitable
for a polyester
innerliner.

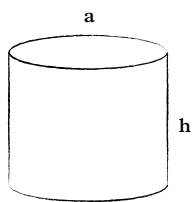



BRLD6060

CLD

BD40Z

BD40WS

	a	b	h	w	m ³
BD4040	40cm	40cm	40cm	20kg	36l
CLD5050	50cm	50cm	50cm	30kg	89l
BRLD6060	60cm	30cm	60cm	45kg	69l
BD4040	15,75"	15,75"	15,75"	44lbs	9,5gal
CLD5050	19,69"	19,69"	19,69"	66lbs	25,5gal
BRLD6060	23,62"	11,81"	23,62"	99lbs	18,2gal

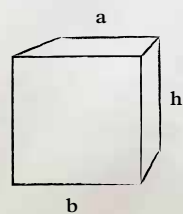
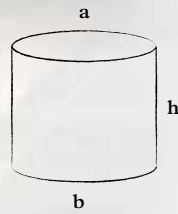

CL

CLB

	a	b	h	w
CLB60	56cm	66cm	59,5cm	85kg
CLB60	22"	26"	23,4"	187lbs

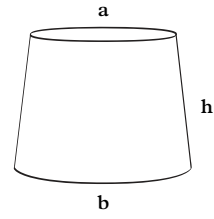

CLE

	a	b	c	h	w
CLE30	28,5cm	40cm	5cm	28cm	20kg
CLE30	11,2"	15,7"	2"	11"	44lbs

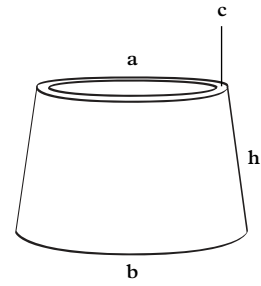

CLE

	a	b	c	h	w
CLE50	49cm	58cm	5cm	34cm	65kg
CLE60	60cm	65cm	6cm	51,5cm	90kg
CLE50	19,3"	22"	2"	13,4"	143,3lbs
CLE60	23,9"	25,6"	2,4"	20,3"	198,4lbs

*Extra option:
with or without
golden rim*

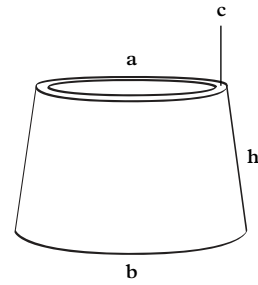

CLG

	a	b	h	w	m ³
CLG	60cm	63cm	53cm	65kg	113l
<i>CLG</i>	23,6"	24,8"	20,9"	143lbs	29,9gal

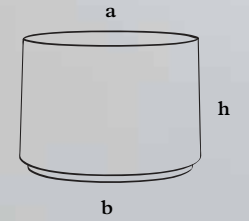

CLG60R/Z21/GLAZE

CLG60R/V8/GLAZE



CLG



CLG60G/V11/GLAZE

CLG60W/G20/GLAZE



CLG60C/W17/HALF GLAZE

CLG60W17/C/HALF GLAZE



W/G

Z/WS

W/WS

W/Z

W/WS

Z/G

	a	h	w
CLK40	40cm	40cm	25kg
CLK50	50cm	50cm	35kg
CLK60	60cm	65cm	50kg
CLK80	80cm	45cm	70kg

CLK40	15,7"	15,7"	55lbs
CLK50	19,6"	19,6"	77lbs
CLK60	23,6"	25,6"	110lbs
CLK80	31,5"	17,7"	155lbs

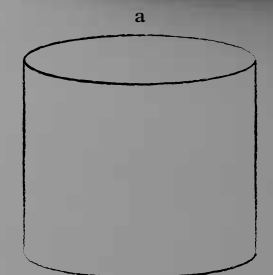

Only standard colours possible.

CLK

CLO50



CLO80

	a	b	h	w
CLO50	46cm	43cm	50cm	40kg
CLO80	57cm	51cm	80cm	60kg
CLO50	18,1"	16,9"	19,9"	88lbs
CLO80	22,4"	20"	31,5"	132lbs

Only standard colours possible.

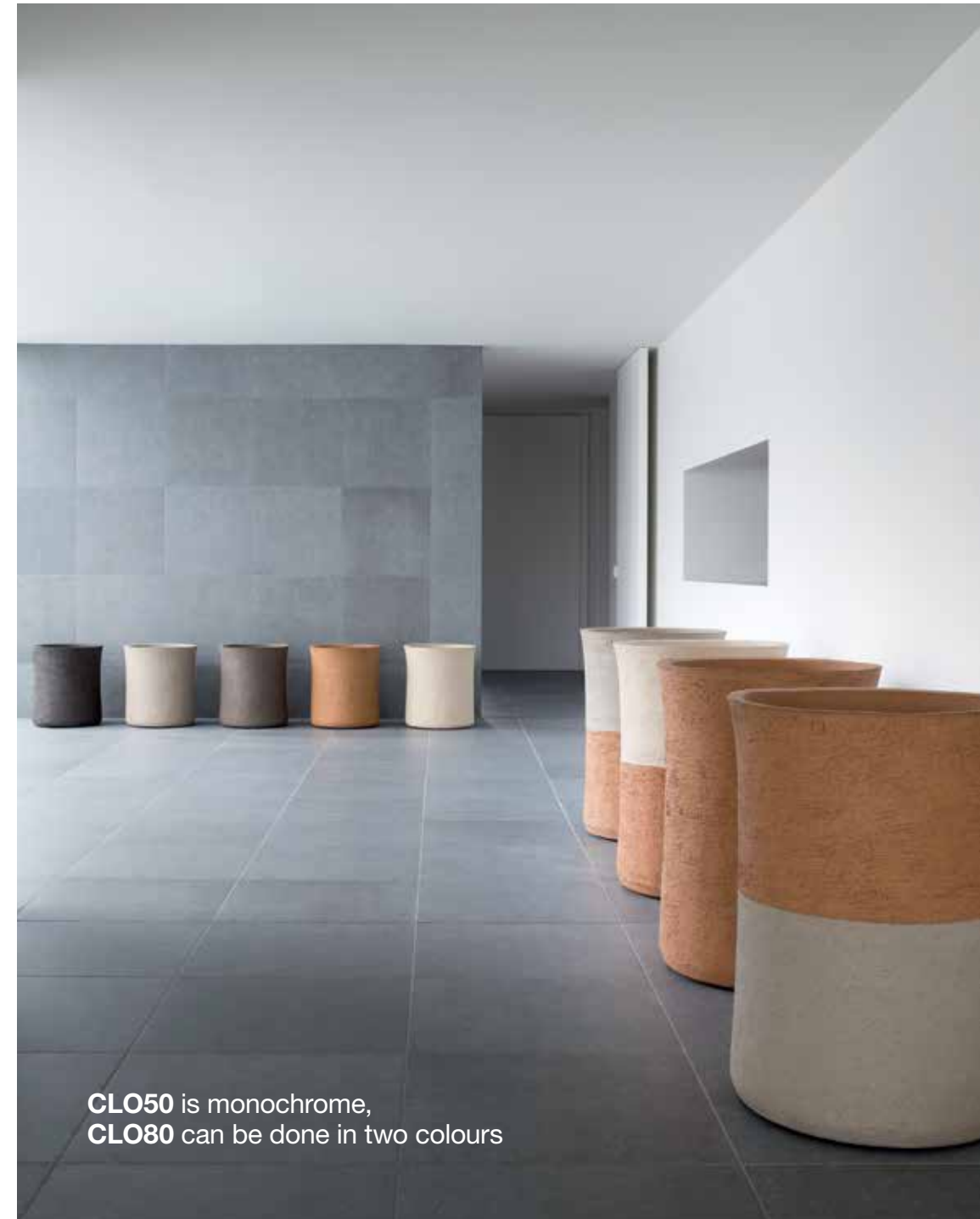
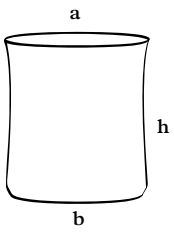

CLO50 is monochrome,
CLO80 can be done in two colours



CLO

CLO50 and **CLO80** series at
RHS Flower Show, planted
with *Sarracenia x corteii* 'Clare Soper'

CLS

	a	h	w
CLS50	50cm	50cm	40kg
CLS60	60cm	65cm	50kg
CLS80	80cm	45cm	70kg
CLS50	19,7"	19,7"	88lbs
CLS60	23,6"	25,6"	110lbs
CLS80	31,5"	17,7"	155lbs

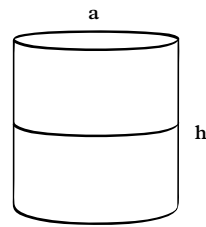

CLT

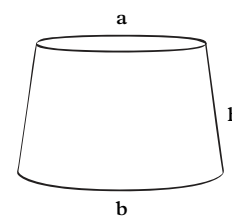

	a	b	h	w	m ³
CLT55	42cm	56cm	52cm	35kg	65l
CLT80	69cm	82cm	52cm	65kg	185l
CLT55	16,5"	22"	20,4"	77,2lbs	17,2gal
CLT80	27"	32,2"	20,4"	143,3lbs	48,9gal

With coloured engobe accents, the new trapezium shaped CLT vessels with their horizontal strict lines give counterweight to verticality of modern architecture.



COP

	a	b	c	d	h	w
COP40	42cm	47cm	47cm	37cm	36cm	30kg
COP60	60cm	54cm	43cm	53cm	49,5cm	61kg
COP40	16,5"	18,5"	18,5"	14,6"	14,2"	66lbs
COP60	23,6"	21,3"	14,2"	16,9"	19,5"	135lbs

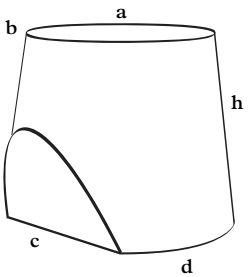

COP40



COP60

CS

	a	h	w
CS60	28cm	60cm	15kg
CS60	11,2"	23,6"	33lbs

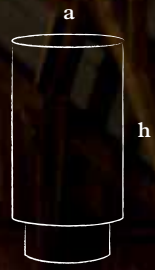

CS

	a	h	w
CS45	45cm	45cm	15kg
CS55	45cm	55cm	20kg
CS45	17,7"	17,7"	33lbs
CS55	17,7"	21,7"	44lbs

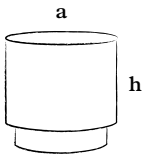



CSD15C - W

CS25 - OPTION 5

CS10V11/Z

CS

	a	h	w
CS10	44cm	10cm	5kg
CS15	44cm	15cm	5kg
CSD15	44cm	15cm	15kg
CS25	44cm	25cm	15kg
CS10	17,3"	3,9"	11lbs
CS15	17,3"	5,9"	11lbs
CSD15	17,3"	5,9"	33lbs
CS25	17,3"	9,8"	33lbs

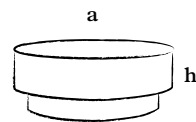

CS25

OPTION 3

OPTION 2

OPTION 1

OPTION 4



Clay, Heritage — Nature of home

CSD

— After your body, your home is the next most personal thing in life. It's a retreat, a place where you should be able to close the door on the rest of the world and feel secure. In times of economic turmoil and political instability, it's been harder than ever to close that door to the rest of the world. Homes have become houses, which in turn have become statistics related to numbers and abstract figures. Anxieties of daily life outside have been brought indoors at a time when we all need somewhere to retreat to more than ever. We build our homes and surround ourselves with objects, materials and furnishings that we trust in; those with which we like to live and connect. We identify with the space in which we live and use home as a shelter to disconnect from an often too impersonal urban context. We strive to create intensely personal spaces where evidence of life brings character and comfort. We don't have to know the owners to see that these are happy abodes.

— What's more important, happiness doesn't come from adopting a design-by-numbers approach to building or furnishing. By introducing clay into the realm of furniture with its pots, pebbles and vessels, Atelier Vierkant

supports the use of a material that humans have been able to connect with ever since ancient times. The heritage embedded in clay therefore returns in the round-shaped bathtubs, in the complex body of the stone series, in coffee tables, plates, stools, vases and larger vessels. The imperfections of each shape and piece make it unique and priceless.

— Working in clay, letting the rough materials run through our hands, modelling and creating are actions that, as artisans, make us experience the sense of home. «Heimweh», a German word without a proper translation in English, indicates nostalgia and the sense of missing home, the place we belong. We often forget the difference between «knowing something about a place» and «actually being there», experiencing it with all our senses and eventually letting it become a «home» for us. In fact, home is, by definition, the place we belong to, the place we can connect with easily, the place where we work, live, and spend time with family and friends. We feel at home in those places where we can connect with our Heritage and where we revive memories of our ancestors. Instead of fake, artificial materials

Clay, Heritage — Nature of home



like plastic and composites which are not what they pretend to be, we move towards materials that simply are what they are: wood, glass, metal, and clay. Thanks to the constant contiguity with them, people go back to their origins, to their Heritage.

— The roots of the relation, sometimes synergic and sometimes dichotomic, between man and clay are well described by the words of Edmund de Waal. Edmund de Waal, a British ceramist, artist and author, has developed throughout his life a special connection with clay and ceramic which goes well beyond the boundaries of mere manufacturing transcending the realm of art, family narrative and philosophic and historic research. In his essay *Terra Incognita*, de Waal clearly highlights that, despite its presence in every place and aspect characterizing our daily life, clay is a material that we have always taken for granted, being almost invisible in the most common aspects of society. Just in relatively recent times it has been re-discovered in art. However, in de Waal's perspective, being invisible does not mean being unimportant. In fact, clay has always played a fundamental role in building our practical and artistic notions, and it has been



Clay, Heritage — Nature of home

characterized by multiple deep connotations throughout history, sometimes being a metaphor for art itself. In the realm of art, de Waal argues, its ubiquity and its low-profile but constant presence in everyone's common life have been used «as a medium to penetrate mass consciousness and to

communicate strong messages». However, it also true that the boundaries between art and crafts, between practical and artistic nature and between the functional and the aesthetic are blurred and not sharp. In fact, de Waal points out, it was just during the 20's and 30's of the last

century that pottery started to be acknowledged as a means through which the artist could express a pure, proactive and self-renovating art, detached from any intention and form of simulation. Color also was thought as being an integral and indissoluble part of the clay body, not applied afterwards just to embellish the shape but thought together with it in order to propel the expression of emotion, feelings and fascination.

— Terra Incognita also explores the biblical origin of man, who was born and shaped from clay. The idea of clay as human flesh inspired the common imagery and metaphor of the human body as a clay vessel, where the sounds of your vital functions are echoed by the shapes of its shell. As sculptural, resistant material, clay can also be seen not just as a metaphor of human body but also as something that humans strive to shape at their will, sometimes struggling with it in the actions of cutting, shaping, molding the material in an artificial shape. The fascination we have with this material comes indeed from its dichotomic nature and its versatility to be either art or craft, or to be both at the same time, and it will never fall out of fashion because Clay embodies both our inner and external world.

Clay, Heritage — Nature of home

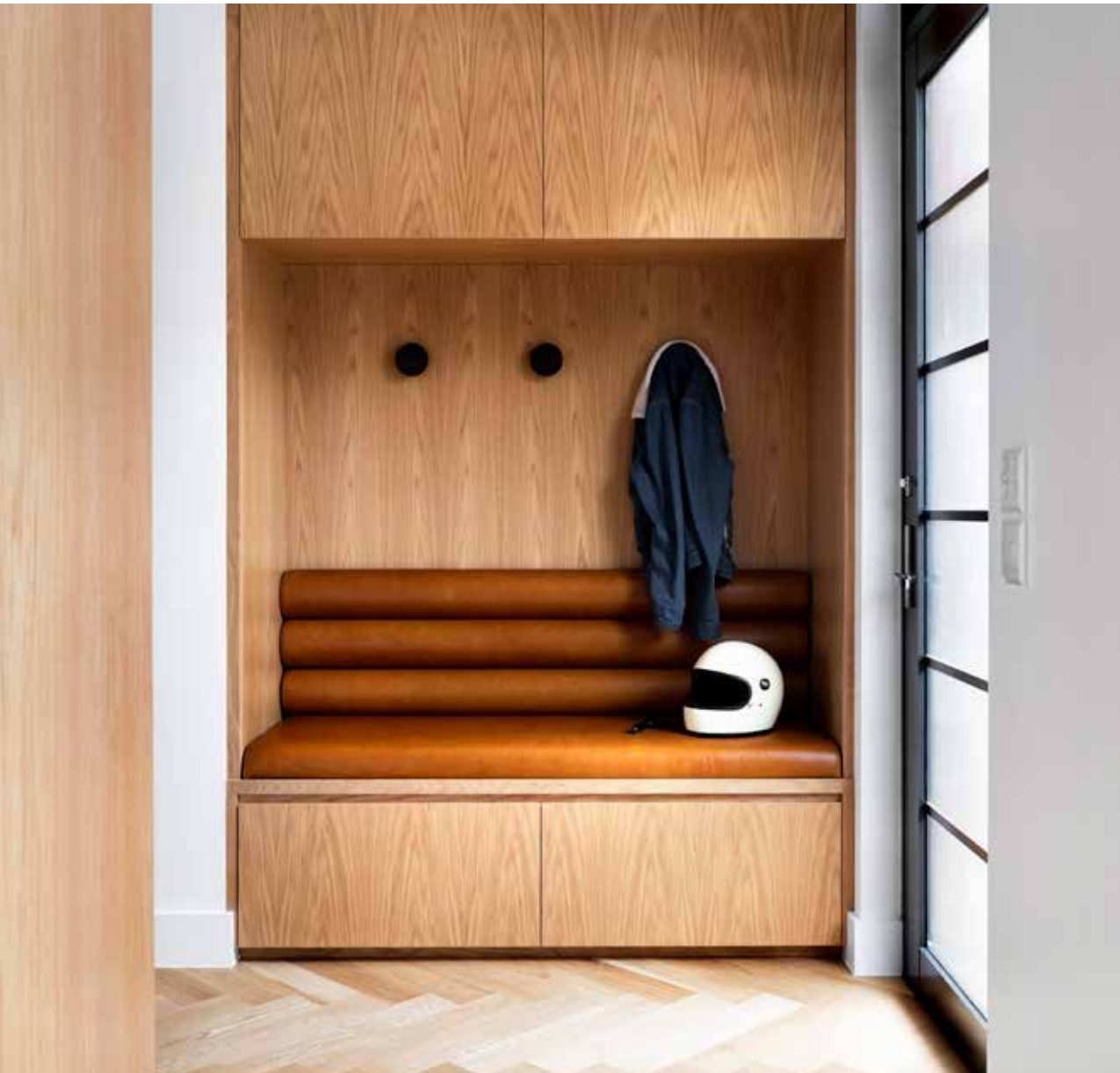



CS & CSD
at Salone del Mobile,
Molteni booth

CSD

CV

	a	h	w
CV70	70cm	42cm	70kg
CV70	27,6"	16,5"	155lbs

With a rough texture

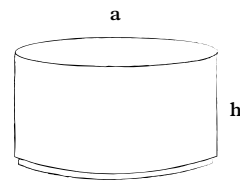

DMB

	a	b	c	h	w	m ³
DM80	69cm	47cm	80cm	77cm	70kg	235l
DMB80	69cm	47cm	80cm	77cm	90kg	235l
DM80	27,1"	18,5"	31,5"	30,3"	154lbs	62,1gal
DMB80	27,1"	18,5"	31,5"	30,3"	198lbs	62,1gal

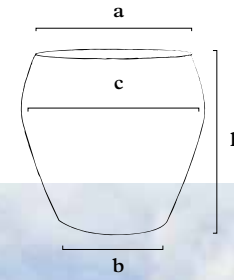

DMB80
in white finish

*DM (left) has a standard texture T0
DMB80 (right) has texture T8*



DM



DMB

DM DMB

DC DCE DCT

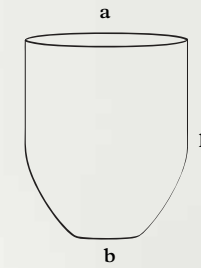

	a	b	h	w
DC30	28cm	13cm	32cm	8kg
DC25	23,5cm	9,5cm	32cm	6kg
DC30	11"	5,1"	12,6"	17,6lbs
DC25	9,3"	3,7"	12,6"	13,2lbs



DCT

DCE

DC DCE DCT

	a	b	h	w
DC50	33cm	19cm	52cm	20kg
DC70	51cm	24cm	70cm	35kg
DC100	66cm	35cm	91cm	80kg
DC50	12,9"	7,4"	20,4"	44lbs
DC70	20,1"	9,4"	27,5"	77lbs
DC100	26"	13,8"	35,8"	176lbs

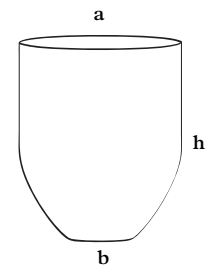

DCE70 - G/G20

DCE50 - WW/G19

DCE50
WS/W16



KABA

DC DCE DCT



DCE50 - WS/BL2



DC50 - BL
FULL TEXTURE



DCE50 - BL/W17

DT

	a	b	c	h	w
DT40	49cm	64cm	62cm	37cm	45kg
DT50	47cm	69cm	60cm	45cm	60kg
DT40	19,3"	25,2"	24,4"	14,6"	99lbs
DT50	18,5"	27,2"	23,6"	17,7"	132lbs

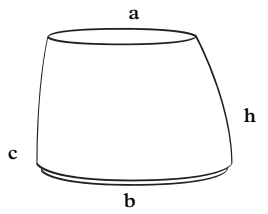

V8+

V12

WW

V12

V8

V8+

EM

	a	b	c	d	h	w	m ³
EM60	60cm	43cm	23cm	39cm	39cm	30kg	44l
EM70	70cm	45cm	17cm	50cm	39cm	40kg	57l
EM80	80cm	57cm	33cm	53cm	45cm	60kg	118l
EM90	90cm	69cm	37,5cm	61cm	49cm	75kg	150l
EM100	100cm	67cm	24cm	74cm	56cm	90kg	170l
EM60	23,6"	16,9"	9,1"	15,3"	15,3"	66lbs	11,6gal
EM70	27,5"	17,7"	6,7"	19,7"	15,3"	88lbs	15gal
EM80	31,5"	22,4"	13"	20,9"	17,7"	132lbs	31,2gal
EM90	35,4"	27,1"	14,8"	24"	19,2"	165lbs	39,6gal
EM100	39,4"	26,3"	9,5"	29,1"	22"	198lbs	44,9gal

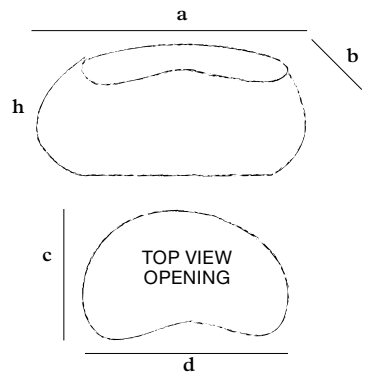



EM60 with
Euphorbia enopla,
Bluet Gent

EM





EM80
in black anthracite
at Grand&Johnson



FGS70BR24/WS

FGS

FGS FGR

	a	h	w
FGS60	30cm	58cm	15kg
FGS70	35cm	68cm	25kg
FGR55	23,5cm	55cm	15kg
FGR65	27cm	65cm	25kg
FGS60	11,8"	22,8"	33lbs
FGS70	13,8"	26,8"	55lbs
FGR55	9,2"	21,7"	33lbs
FGR65	10,6"	25,6"	55lbs

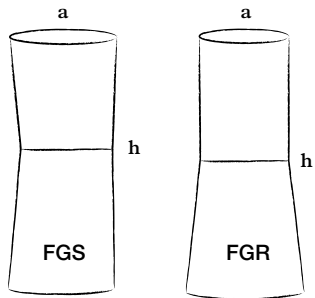



FGR65W/R25



FGS70WW/V11



FGR55V11/W



FGS60W/R25



FGS60BR24/W





FG and FGS
Gasholders, London

FGS SEAT

	a	h	w
FGS SEAT	40cm	61cm	55kg
FGS SEAT	15,7"	24"	121lbs

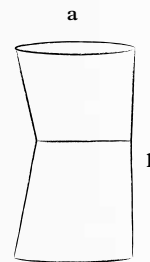

*Possible with or without
colour top.*



GR

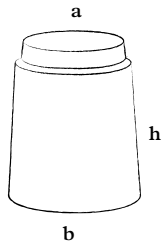

	a	b	h	w
GR25	19,5cm	23cm	34cm	15kg
GR40	28,5cm	38cm	36cm	25kg
GR60	51cm	68cm	60cm	65kg
GR70	38cm	50cm	68cm	55kg
GRS40	23,5cm	40cm	33cm	20kg
GRS50	48cm	55cm	42cm	35kg
GR25	7,68"	9,06"	13,39"	33lbs
GR40	11,22"	14,96"	14,17"	55lbs
GR60	20"	26,8"	23,6"	143lbs
GR70	15"	19,7"	26,8"	121lbs
GRS40	9,25"	15,75"	12,99"	44lbs
GRS50	18,9"	21,7"	16,5"	77lbs

GRS

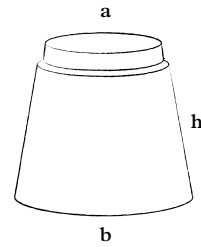

The **GR** line is presented as still life, and comes in both a black smooth finish, as well as white washed semi mat engobe, with subtle black rim.





GR70

GR60

GRS50



GRS50 RIM 4,5CM/1,8"



HK

	a	h	w	m ³
HK40	66cm	29cm	20kg	24l
HKL40	69cm	19cm	15kg	30l
HK60	90cm	57cm	45kg	125l
HK75	98cm	65cm	70kg	205l
HK90	107cm	72cm	95kg	290l
HK130	127cm	87cm	150kg	565l

HK40	26"	11,4"	45lbs	6,3gal
HKL40	27,1"	7,5"	33lbs	7,9gal
HK60	35,4"	22,4"	100lbs	33gal
HK75	35,6"	25,6"	154lbs	54,2gal
HK90	47,2"	35,4"	210lbs	76,6gal
HK130	50"	34,3"	330lbs	149,3gal

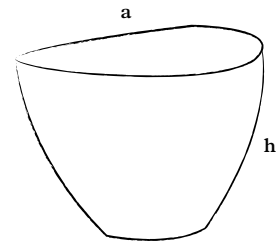

SIDE VIEW

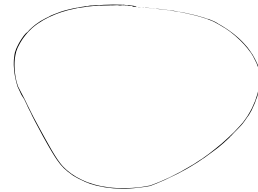

TOP VIEW





The Port House is the head office of the Antwerp Port Authority. Designed by Zaha Hadid, who died unexpectedly a couple of months before completion of the building, the new building symbolises the dynamic, reliable, ambitious and innovative nature of the Port of Antwerp. It is the daily workplace of 500 employees of the Port Authority and it acts as a meeting place for the many international contacts.



HK

HK

HK130

HK40

HK90

HK60





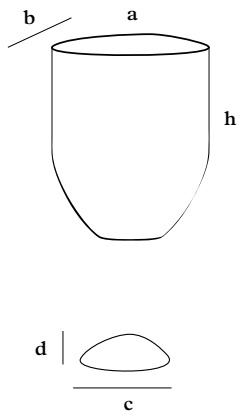

	a	b	c	d	h	w	m ³
HKH80	60,5cm	47cm	38cm	27,5cm	81cm	45kg	115l
HKH90	64,5cm	53cm	40cm	30cm	90cm	60kg	146l
HKH80	23,8"	18,5"	14,9"	10,8"	31,8"	99lbs	30.4gal
HKH90	25,3"	20,8"	15,7"	11,8"	35,4"	132lbs	38.6gal



HV

	a	b	h	w
HV50	48cm	20cm	28cm	20kg
HV60	59cm	25cm	33cm	25kg
HV80	78cm	37cm	53cm	45kg
HV130	130cm	80cm	65cm	150kg
HV140	140cm	90cm	100cm	200kg
HVR140	140cm	90cm	100cm	200kg
HV50	18,9"	7,9"	11"	45lbs
HV60	23,2"	9,8"	13"	55lbs
HV80	30,7"	14,6"	20,9"	100lbs
HV130	51,2"	31,5"	25,6"	330lbs
HV140	55,1"	35,4"	39,4"	440lbs
HVR140	55,1"	35,4"	39,4"	440lbs

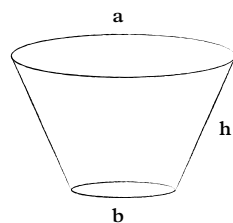

HVF

	a	b	h	w
HVF80	78cm	37cm	53cm	65kg
HVF80	30,7"	14,6"	20,9"	145lbs

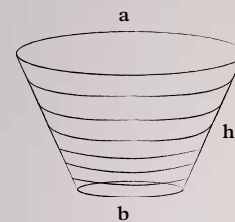

HM

	a	b	c	h	w
HM65	65cm	52cm	97cm	48cm	90kg
HM90	88cm	52cm	119cm	49cm	110kg
HM65	25,6"	20,5"	38,2"	18,9"	198lbs
HM90	34,6"	20,5"	46,9"	19,3"	243lbs

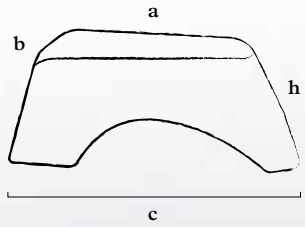

HM90



HM65



IP



ZV8+



	a	b	c	h	w
IP90	43cm	92cm	4cm	74cm	210kg
IP90	16,9"	36,2"	1,6"	29,1"	462lbs

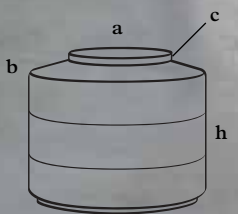

KB

	b	h	h ²	w
KB40	40cm	51cm	51cm	50kg
KB45	45cm	51cm	51cm	60kg
KBS40	40cm	51cm	44cm	50kg
KBS45	45cm	51cm	45cm	60kg

KB40	15,7"	20,1"	20,1"	110lbs
KB45	17,7"	20,1"	20,1"	132lbs
KBS40	15,7"	20,1"	17,3"	110lbs
KBS45	17,7"	20,1"	17,7"	132lbs

KBS

*KB40 and KB45 are
straight pedestals
KBS40 and KBS45
are slightly slanted*

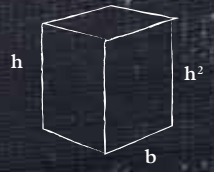

*Not suitable for
public areas*

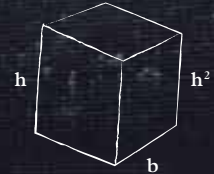

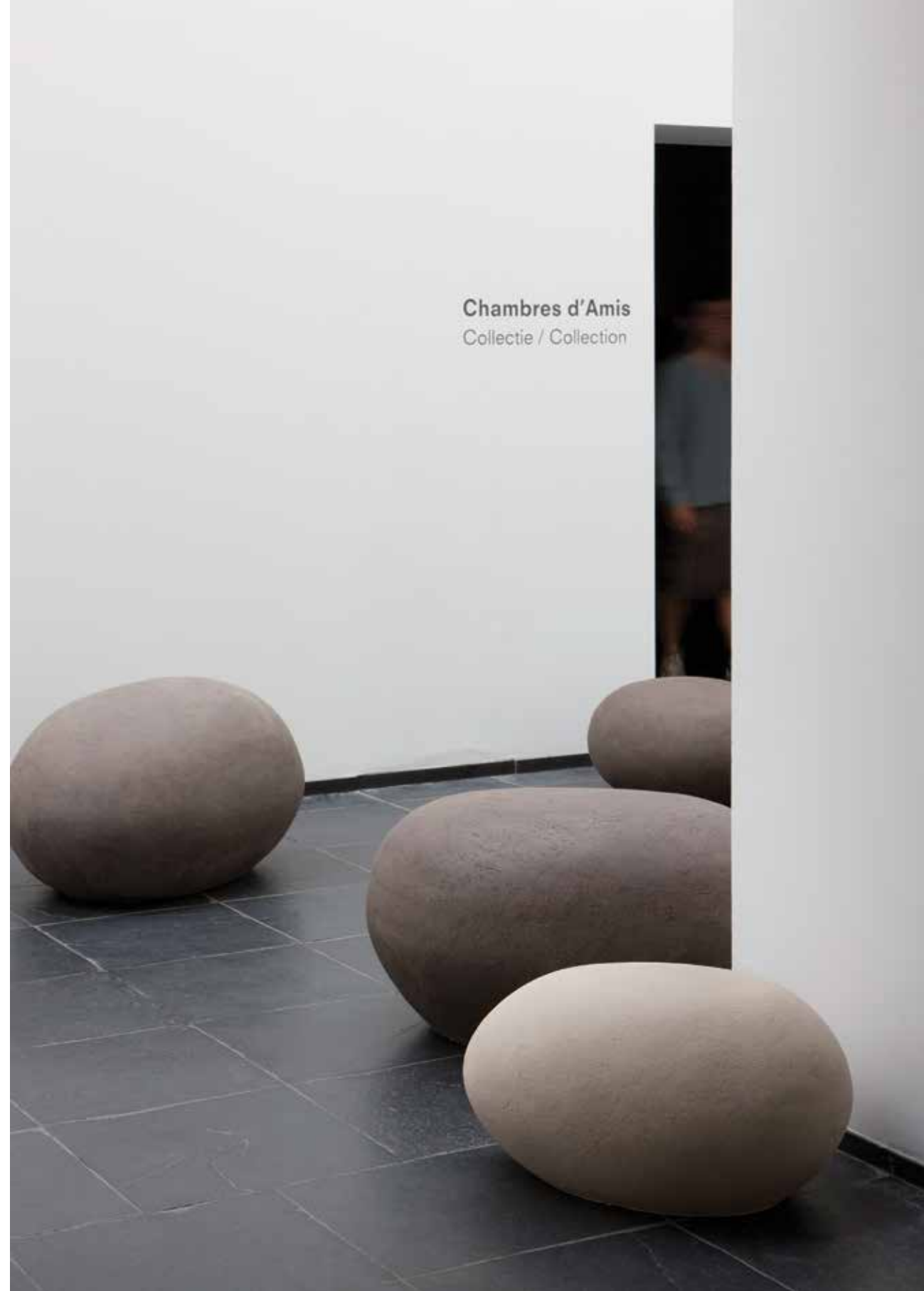

Chambres d'Amis
Collectie / Collection

K

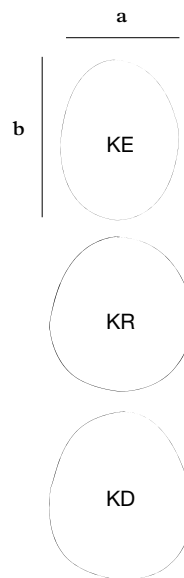

	a	b	h	w
KE70	50cm	68cm	36cm	45kg
KE100	73cm	100cm	54cm	100kg
KR70	56cm	61cm	38cm	45kg
KR85	70cm	78cm	45cm	75kg
KR100	86cm	93cm	52cm	100kg
KD70	55cm	68cm	38cm	45kg
KD85	70cm	83cm	48cm	75kg
KD100	86cm	102cm	56cm	100kg
KE70	19,7"	26,8"	14,2"	99lbs
KE100	28,7"	39,4"	21,3"	220lbs
KR70	22"	24"	15"	99lbs
KR85	27,6"	30,7"	17,7"	165lbs
KR100	33,9"	36,6"	20,5"	220lbs
KD70	21,7"	26,8"	17,3"	99lbs
KD85	27,6"	32,7"	18,9"	165lbs
KD100	33,9"	40,2"	22"	220lbs

K



K

TORAYA CAFÉ · AN STAND



KL, KE, KR
Toraya Café, Tokyo

K

K series
Roche Pharmaceuticals,
Anderlecht



K





KR120



	a	b	h	w
KR120	120cm	109cm	70cm	150kg
KR120	47,2"	42,9"	27,6"	330lbs

Atelier Vierkant introduces engraving in different models like shown on this **K**-series. Our designers are open to discuss the different possibilities.





KL

	a	h	w
KL120	116cm	30cm	60kg
<i>KL120</i>	45,6"	11,8"	132lbs

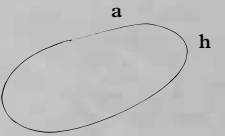

KH

	a	b	c	d	h	w
KH1	55cm	65cm	34cm	25cm	37,5cm	75kg
KH2	56,5cm	70cm	34cm	25cm	39cm	75kg
KH1	21,5"	25,6"	13,4"	9,8	14,8"	165lbs
KH2	22"	27,6"	13,4"	9,8	15,3"	165lbs

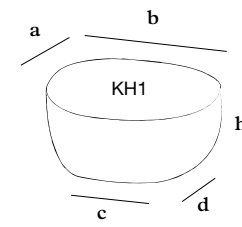

TOP VIEW

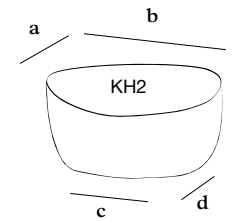

TOP VIEW







KH and **K** seats at Sampo
Museum of Art, Tokyo

KHL

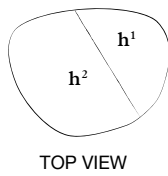
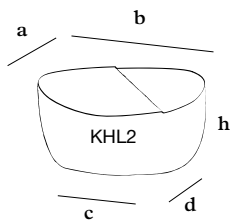
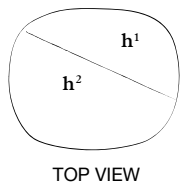
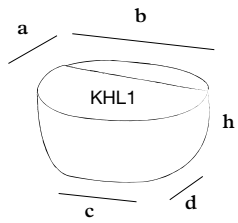

	a	b	c	d	h1	h2	w
KHL1	54cm	66cm	34cm	25cm	35,5cm	37,5cm	50kg
KHL2	59cm	73cm	34cm	25cm	36cm	38cm	50kg
KHL1	21,3"	26"	13,4"	9,8"	13,9"	14,8"	110lbs
KHL2	22"	27,6"	13,4"	9,8"	14,2"	15"	110lbs



KHL
Como Dempsey Hill,
Singapore

KH-leather

Atelier Vierkant introduces the marriage of leather with clay; the particular high quality leather finish on top of the **KH** pebbles.

	a	b	c	d	h	w
KH1	55cm	65cm	34cm	25cm	37,5cm	50kg
KHL2	59cm	73cm	34cm	25cm	38cm	50kg
KH1	21,5"	25,6"	13,4"	9,8"	14,8"	110lbs
KHL2	22"	27,6"	13,4"	9,8"	15"	110lbs

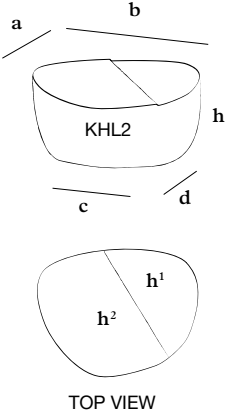
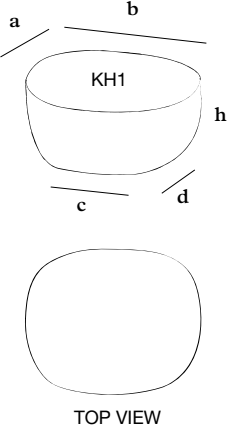

Color options:



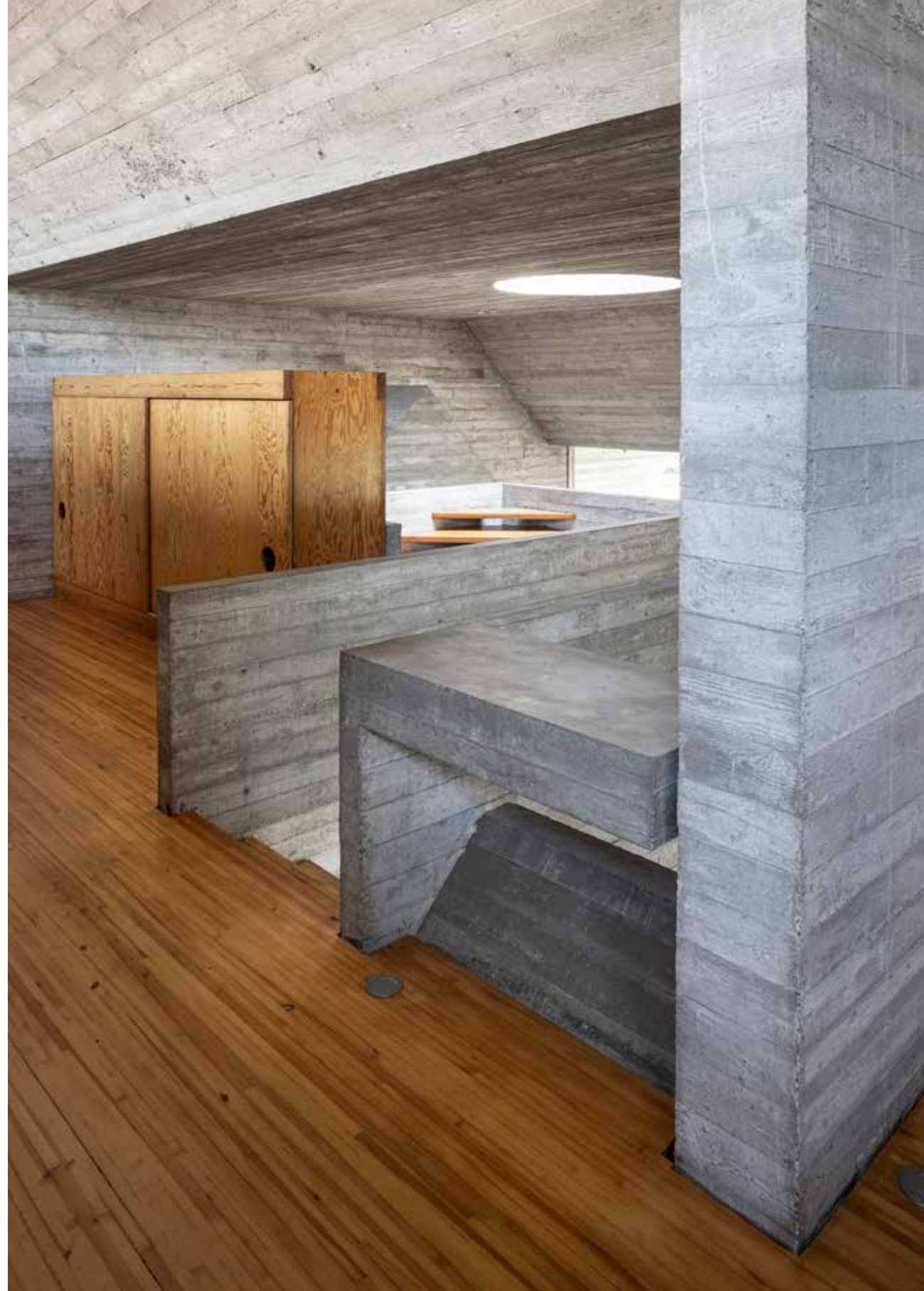

Private residence,
entrarchitecture



Clay, a journey of Sustaina- bility & Durability

— We have always been working with clay, a natural material which is as simple as strong and robust. Produced thanks to hand made work and acquired knowhow, Atelier Vierkant pots are made to last. In this perspective, our products are made to last for a lifetime, and oppose to the consumistic, short-term trend our society is characterised by, according to which products are made to last few years before breaking and being thrown away in the garbage.

Clay, Sustainability Durability





Clay, Sustainability Durability

— Thanks to such consciousness of long-term perspective, our pots, pebbles and benches become companions, friends that acquire personal meaning with time and that are inserted in the narrative of a place, having something to tell about your garden, your house and keeping the memories of these sites.

— Each pot of Atelier Vierkant is unique and tells a different story. This is true also for the entirely hand made clay pots of Atelier Vierkant. Their natural connotation implies the communion and the conjunction of the four natural element our world is made of- earth, fire, air and water. Earth and water recalls the physical status in which we find clay; air relates to the drying process in which air-blowing pipes partially eliminate the water trapped in clay particle; fire refers to the firing process of clay, in which pots and seats are rolled in to gigantic ovens and fired at extremely high temperatures. However, these elements would never become something concrete without the addition of a fifth element, which allows them to become a finished product of outstanding quality: human passion. Passion for what we do and for what we can produce with our creativity and inspiration. In fact, the story our pots tell is a narrative made of inspiration, but also of perspiration. Thomas Edison said it best: «Genius is 1 percent inspiration and 99 percent perspiration». It is true that it is always

creative inspiration that leads to genuine, frankly contemporary designed pots. But the execution requires a lot of efforts and sweating. The synergy between inspiration and perspiration often works well: inspiration strengthens perspiration, while perspiration nurtures inspiration. In this process dedication, discipline, organization and a lot of hard work are indispensable elements. We have developed and perfected traditional skills and special production techniques. This allows us to maximize the this synergy realizing the forms that creativity has imagined and demonstrating that at Atelier Vierkant the art of craftsmanship is not dead. Instead, arts and crafts are at their best.

— Durability does not only refer to memory and to the narrative of a place. Instead, it also refers to physical durability. Natural clay, fired at 1200°C, can withstand different harsh climate conditions such as frost and heat, and resists to UV rays. This means especially that the shape will not be subjected to alterations and that colours will not fade away. This is the reason why our pots and seats are chosen to enrich beautiful gardens and outdoor areas all around the world, in different atmospheric conditions, and this is also why it is extremely common to see our vases covered with soft snow or our pebbles silted in warm sand: from Hawaii to Saudi Arabia, from Japan to Spain.

Clay, Sustainability Durability

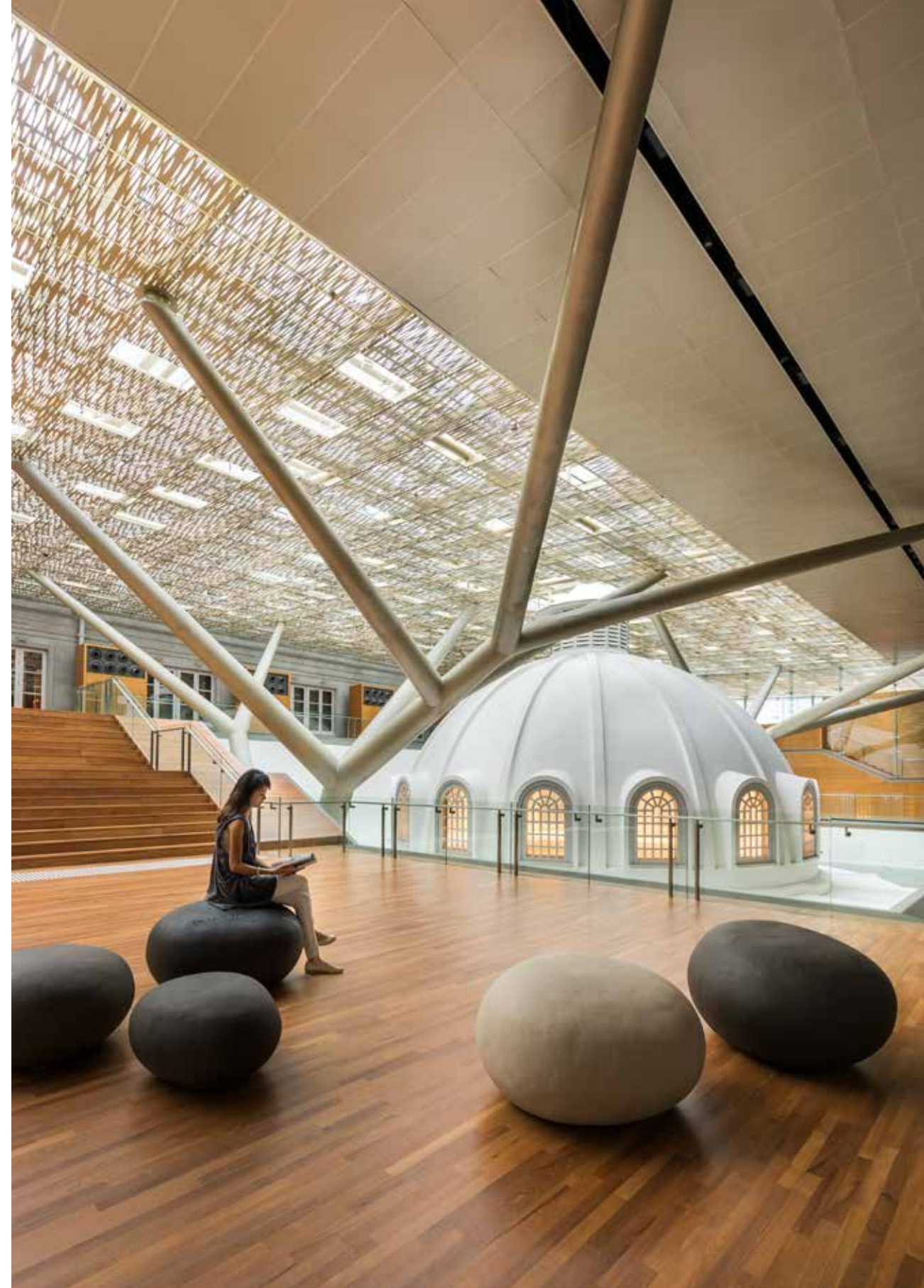



KHO

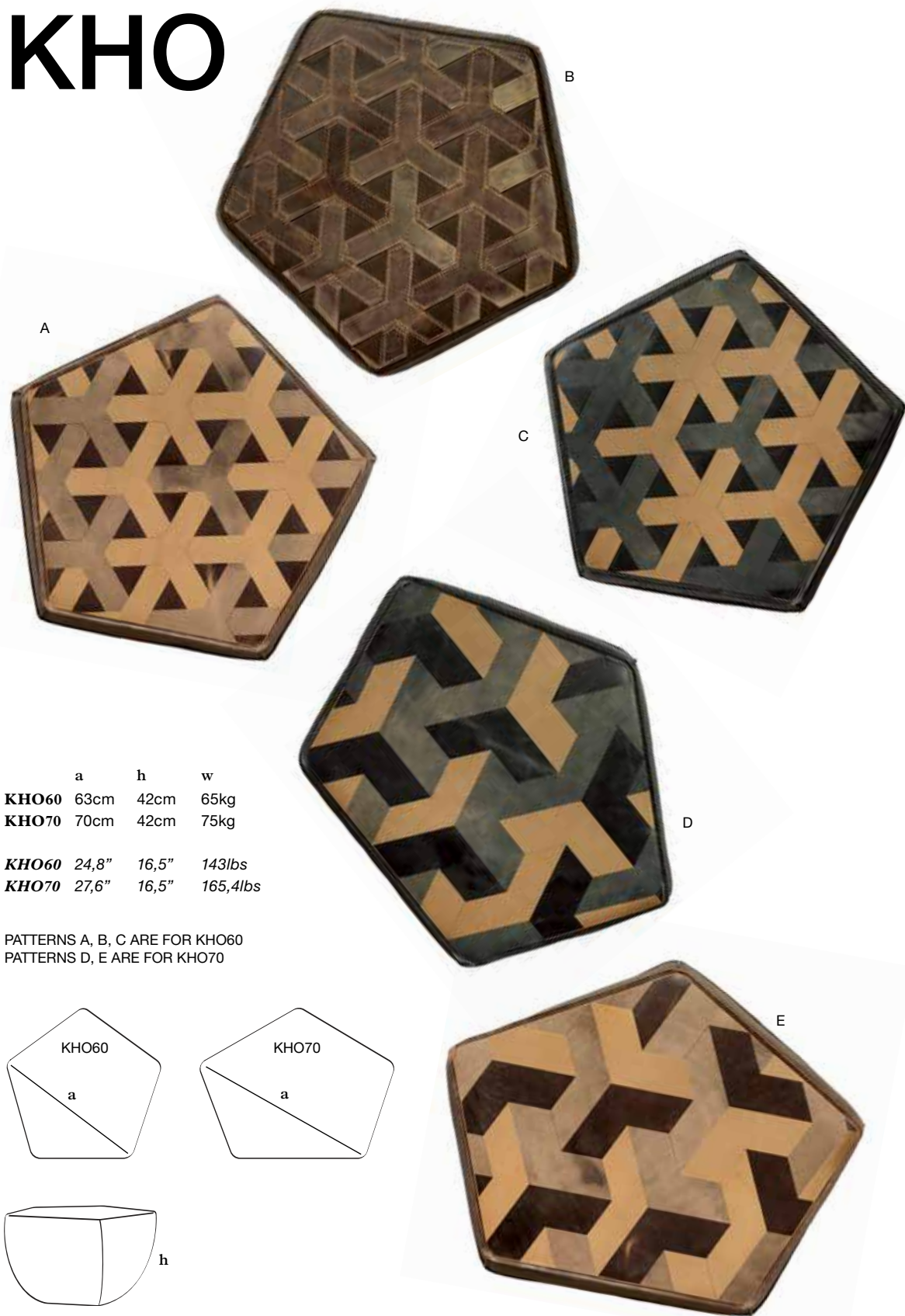

	a	h	w
KHO60	63cm	42cm	65kg
KHO70	70cm	42cm	75kg
KHO60	24,8"	16,5"	143lbs
KHO70	27,6"	16,5"	165,4lbs

PATTERNS A, B, C ARE FOR KHO60
PATTERNS D, E ARE FOR KHO70

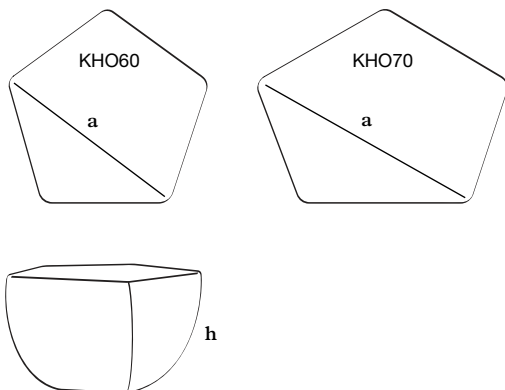

STAM is the Ghent city museum. It presents the story of the city of Ghent. A permanent circuit leads visitors along a chronological trail of objects and multimedia which trace the development and growth of Ghent. Temporary exhibitions explore the concept of 'urbanity' from different angles. STAM's real showpiece, its raison d'être, is the city itself. A visit to the city museum is not complete without a visit to Ghent.

KKA

	a	h	w
KKA50	65cm	44cm	50kg
KKA80	80cm	47cm	80kg
KKA100	108cm	58cm	120kg
<i>KKA50</i>	17,3"	26,6"	110lbs
<i>KKA80</i>	31,5"	18,5"	176lbs
<i>KKA100</i>	42,5"	22,8"	264lbs

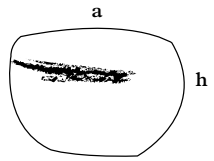



KKA

KKA
Corales Suites,
Tenerife



KKB

	a	h	w
KKB50	63cm	52cm	45kg
KKB70	75cm	63cm	80kg
KKB50	24,8"	20,4"	99lbs
KKB70	29,5"	24,8"	176lbs

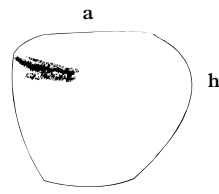

KKC

	a	h	w
KKC50	54cm	48cm	45kg
KKC70	67cm	60cm	80kg
KKC50	21,3"	18,9"	99lbs
KKC70	26,4"	23,6"	176lbs

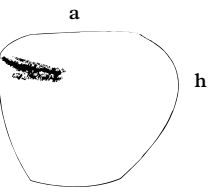

KX

	a	b	h	w
KX80	80cm	104cm	48cm	120kg
KX80	31,5"	40,9"	18,9"	264lbs

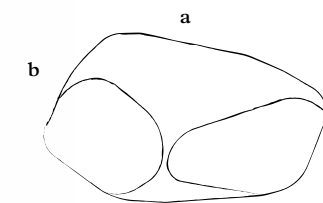

KX Series
at Kåseholm Slott,
Sweden



LC25 and LC50
at Cosmopolitan,
Warsaw



LC

	a	b	h	w
LC25	25cm	50cm	75cm	30kg
LC50	50cm	50cm	75cm	40kg
LC25	9,8"	17,9"	29,5"	66,1lbs
LC50	17,9"	17,9"	29,5"	88,2lbs

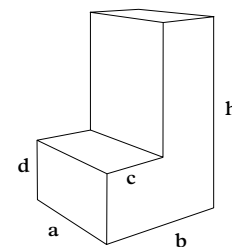

LPS

	a	b	h	w
LPS60	28cm	65cm	24cm	20kg
LPS80	34cm	80cm	32cm	30kg
LPS60	11"	25,5"	9,4"	44lbs
LPS80	13,8"	31"	12,5"	66lbs

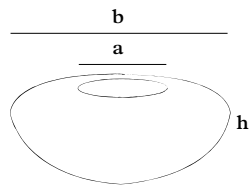

LPS100

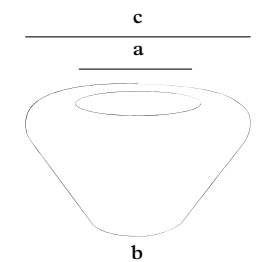

	a	b	c	h	w
LPS100	56cm	47cm	98cm	57cm	95kg
LPS100	22"	18,5"	38,6"	22,4"	209lbs

Possible finishes:

- Grey clay with black engobe
- Black clay with red engobe
- Black clay with grey engobe
- Black clay with green engobe
- White clay with grey engobe

In the centre of a pine forest along the Mediterranean coast, a few kilometres from Barcelona, in the municipality of El Prat de Llobregat, is the Casa Gomis; better known in the field of architecture as *Casa La Ricarda*, or to the locals as The Glass House. Designed by architect *Antonio Bonet Castellana*, disciple and collaborator of José Luis Sert and Le Corbusier, for the marriage of Agnes Bertrand and Ricardo Gomis.

	a	b	c	h	w
LR70	37cm	34cm	74cm	33,5cm	50kg
LR120	60cm	60cm	120cm	52cm	110kg
LR70	14,57"	13,39"	29,13"	13,19"	110lbs
LR120	23,6"	23,6"	47,2"	20,5"	243lbs

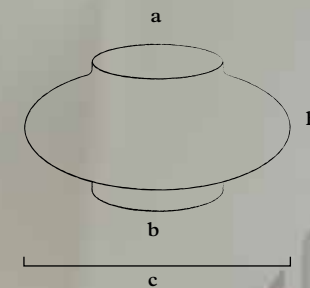

LR

Z

NG/W (H)

NG/W (V)

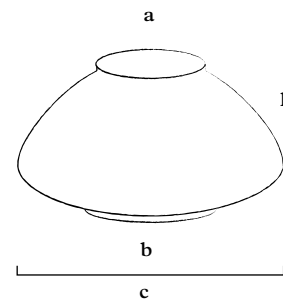

	a	b	c	h	w
LRC70	32cm	40cm	72cm	38cm	60kg
LRC120	52cm	70cm	120cm	57cm	115kg
LRC70	12,6"	15,7"	28,3"	15"	132lbs
LRC120	20,5"	27,6"	47,2"	22,4"	253lbs

The round **LR** and **LRC** bowls, either in monochrome or with extra line detail recall the shallow shapes of the glass work used in the windows and on the separation blocks between the window frames. The bowls are brought in the interior and take the role as furniture, both functionally as well as esthetically relevant.



LRC

LRC



METALLIC



GOLD

LR





SP100Z

LRC120

LR120Z

SP80Z

M

	a	b	h	w
M55	35cm	25cm	55cm	25kg
M80*	53cm	29cm	80cm	50kg
M100	68cm	43cm	100cm	80kg
M120	82cm	55cm	120cm	125kg
M55	13,8"	9,8"	21,6"	55lbs
M80*	20,9"	11,4"	31,5"	110lbs
M100	26,8"	16,9"	39,4"	175lbs
M120	32,3"	21,6"	47,2"	275lbs

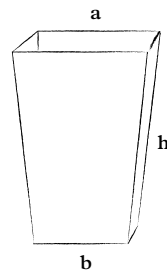

* Suitable for a polyester innerliner.



MA80
at G3 Shopping,
Vienna

MA

	a	b	h	w	m ³
MA80	53cm	29cm	80cm	55kg	120l
MA80	20,9"	11,4"	31,5"	120lbs	5,3gal

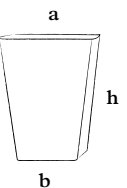

MF

	a	b	h	w
MF60	41cm	29cm	56cm	60kg
MF100	58cm	38cm	98cm	85kg
MF140	71cm	46cm	137cm	140kg
MF60	16,1"	11,4"	22"	132lbs
MF100	22,8"	15"	38,6"	190lbs
MF140	28"	18"	54"	308lbs



MH

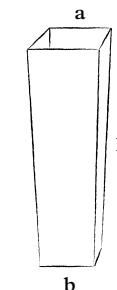

	a	b	h	w	m ³
MH80	25cm	20cm	80cm	20kg	28l
MH100*	30cm	23cm	100cm	35kg	56l
MH120*	32cm	23cm	120cm	40kg	86l
MH130*	33cm	23cm	130cm	45kg	94l
MH80	9,8"	7,9"	31,5"	45lbs	7,4gal
MH100*	11,8"	9"	39,4"	77lbs	14,8gal
MH120*	12,6"	9"	47,2"	90lbs	22,7gal
MH130*	12,9"	9"	51,1"	99lbs	24,8gal

* Suitable
for a polyester
innerliner.



MK

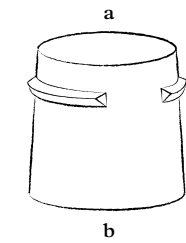

	a	b	h	w
MK30	40cm	42cm	31,5cm	24kg
MK35	46cm	50cm	35cm	35kg
MK40	41cm	42cm	39,5cm	30kg
MK30	15,7"	16,5"	12,4"	53lbs
MK35	18,1"	19,7"	13,8"	77lbs
MK40	16,1"	16,5"	15,6"	66lbs

MHR

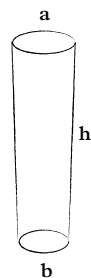

	a	b	h	w	m ³
MHR80	28cm	20cm	80cm	20kg	22l
MHR100*	36cm	28cm	100cm	35kg	56l
MHR120*	36cm	27cm	120cm	40kg	63,5l
MHR80	11"	7,8"	31,5"	45lbs	5,8gal
MHR100*	14,1"	11"	39,4"	77lbs	14,8gal
MHR120*	14,1"	10,6"	47,2"	88lbs	16,8gal

* Suitable for a polyester innerliner.





MLH BENCH

	a	b	h	w
MLH140 Bench	140cm	50cm	45cm	250kg
MLH200 Bench	197cm	49cm	62cm	350kg
<i>MLH140</i> Bench	55,1"	19,7"	17,7"	551lbs
<i>MLH200</i> Bench	77,6"	24,4"	19,3"	770lbs

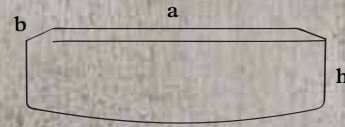

MLH

	a	b	h	w
MLH200	56cm	60cm	193cm	800kg
MLH200	22"	23,6"	76"	1760lbs

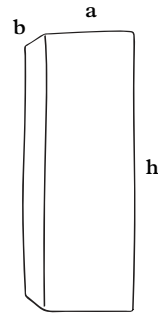

ML

	a	b	h	w
ML120	39cm	39cm	120cm	60kg
ML125	39cm	39cm	125cm	70kg
ML120	15,4"	15,4"	47,2"	132lbs
ML125	15,4"	15,4"	49,2"	154lbs

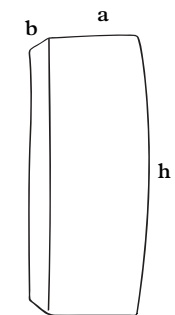



ML

MLH in white and
nordic white,
Strandhotel, Cadzand

MLS

	a	b	h	w
MLS130	48cm	44cm	128cm	95kg
<i>MLS130</i>	18,9"	17,3"	50,4"	209lbs

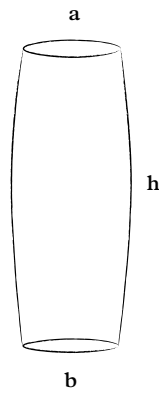

MLS Nordic white
Strandhotel, Cadzand

MR

	a	b	h	w	m ³
MR65	49cm	34cm	65cm	30kg	61l
MR80*	57cm	40cm	76cm	45kg	104l
MR90	80cm	56cm	90cm	100kg	265l
MR130	115cm	85cm	130cm	250kg	590l
MR65	19,3"	13,4"	25,6"	66lbs	16,1gal
MR80*	22,4"	15,7"	29,9"	100lbs	27,5gal
MR90	31,5"	22"	35,4"	220lbs	70gal
MR130	45,3"	33,4"	51,2"	550lbs	156gal

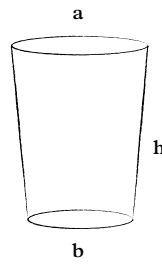

* Suitable for a polyester innerliner.



MR80, MR90 and MR130,
Adriatic Hotel, Rovinj

MR



MR80, MR90 and MR130,
Adriatic Hotel, Rovinj

MRA

	a	b	h	w
MRA45	48,5cm	38,5cm	42,5cm	25kg
MRA55	41cm	30cm	56cm	40kg
MRA45	19,1"	15,2"	16,7"	55lbs
MRA55	16,1"	11,8"	22"	88lbs

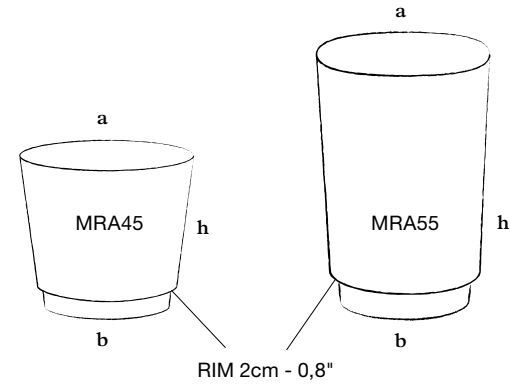



Custom and on demand *Clay* projects

— The term customization derives from the latin word *consuetudo*, *consuetudinis*. Its meaning has been subjected to different variations throughout the centuries: from the original meaning of *habitual practice*, it finally adopted the meaning of *made to measure*. Such measure refers to the need and to the taste of each individual, who is unique and who has exceptional desires and preferences.

Custom and on demand Clay projects



— Atelier Vierkant embraces each individual's idea, inspiration and project designing ad-hoc shapes, mixing colours and structures in order to meet each customer's ideas, making each pot and vessel personal. In fact, the clay labs in Ostend offer the designer and the architect the possibility to give shape to his or her ideas. In the workshop directed by Annette Lantsoght, all the aspect of the project, from the colour to the shape and to the texture are discussed and tailored in order to match and complement perfectly the broader architectural context of the project. The malleability of clay, moreover, allows

also the creation of unique pieces that go far beyond the strict sense and function of a vessel or a seat, such as walls and gigantic shapes. Custom designs are first assessed in terms of technical feasibility and aesthetic. Then, a miniature prototype is created and eventually the piece is reproduced in its real volume and size in order to create the mould. The custom works described in the following pages are just few examples of a vast array of tailored, on-demand works that Atelier Vierkant creates in collaboration with a multitude of architecture and design practices around the world.



Custom and on demand Clay projects

CUSTOM WALL PROJECT IBIZA

— *Sa Ferradura Island*, one of the world's most luxurious private islands, is connected to Ibiza by the small beach of Pas de s'Illa. The project, which consisted of the total refurbishing of an existing house and its garden, was carried out by Romano Arquitectos, an architecture and design studio based in Ibiza. The volume and the footprint of the construction had to be respected due to the specific environmental restrictions of the area -Coastline, landscape protection, wildlife preservation. — At the entrance to the house, a more exposed spot on the island, Atelier Vierkant oversized clay pieces are placed as strong elements

that would recuperate the essentials of the house, leading the guest to the main door. Their custom-made work that Atelier Vierkant produced is unique in terms of size and shape, and the grey nuanced colour variation constitutes a unique pattern thought to complement in a perfect way the architecture of the residence as well as the surrounding natural environment. In fact, the base greyish tone melts easily in the landscape with direct references to the grey of the rockery and of the cliffs.

— Atelier Vierkant deployed its “savoir faire” and its creativity. Together with the studio Romano Arquitectos it was possible to build a teamwork that would resolve the whole challenge in its complexity: developing the concept together, adapting the studio's ideas to the specific technique of the ceramic, finding the right textures and tonalities, studying together the composition of the wall and resolving technical issues – exposures to intense 160 km/h winds. The organization and the coordination with local teams to arrange the transport logistic accounted also for a challenge won thanks to a good team work: bringing the 36 units of 2,30m through the narrow and bumpy dirt road was not as easy as it seems.

V-PALM SPRINGS

— V-Palm Springs outstands in all its uniqueness from the most part of the hotels in the area thanks to its original design and the peculiar role that landscape architecture plays in this project. The design and architecture studio Surface-design took a lead in planning all aspects of the exterior resort areas collaborating with Roy Asaro for the design of the lobby building. Moreover, Surfacedesign worked closely with the City of Palm Springs design review commission and with Filament's operation program to provide a free-spirited and relaxed destination connected to its surroundings. In creating the hotel's many unique design motifs, Surface-design focused on finding inspiration sourcing from the

cultural history and natural setting of Palm Springs.

— The architects provided the team with design cues intended to integrate the client's objective to create a sophisticated and lively destination in the desert. For the entrance, the architect created together with the clays laboratories of Atelier Vierkant a wall of «togetherness». The V-sign, graphically decomposed in different lines and grey tones, is painted in a liquid clay and repeated throughout the wall, conveying a sense of rhythm to the pattern. The positioning of the clay custom-made blocks at different depths illustrates how a static wall construction can turn into a dynamic play of volumes and shades.

Custom and on demand Clay projects



INSTALLATION OF CURVED CLAY WALLS

DOMAT / EMS



Custom and on demand Clay projects

— Located on the right bank of the Rhine river in Switzerland, Domat/Ems is a municipality in the Imboden Region in the Swiss canton of Graubünden. Most areas are forested and embellished by beautiful rivers, glaciers and mountains. The traditional allure of this township is enriched by a contemporary-style roundabout which contains a sculptural structure in the centre, transforming the feature into a unique piece of art in its own right. Tanja Casparis, creative leader for the landscape design company Zingg and author of several projects involving Atelier Vierkant's products, utilised her experience in exterior design and architecture to create a functional structure that optimizes the available space and highlights the potentials of the area while preserving its link to the surrounding natural environment.

— The tailored project conceptualised for this roundabout indeed takes inspiration from the cold colours of grey and green as well as from the shapes of the rocks of the mountains typical of the Alpine environment. Backed by the suggestive and massive mountains covered by forests of evergreens, several huge, rectangular blocks of grey clay with rounded bases stand curved into a circular formation.

Nonetheless, the modern shapes of the structure strongly hint at the area's Alpine cultural heritage. — The imposing clay formation is engraved with the city blazon and the name of the municipality, evoking an image of the famous Dreibündenstein, a marker erected at the intersection of the Three Leagues. The letters as well as the blazon were individually designed and engraved in the clay with extraordinary ability by the hands of the artisans working at Atelier Vierkant. Their experience in moulding perfect curves and shapes allowed them to create a play of different thicknesses and layers allowing the natural light to highlight the contouring lines of each letter and line in the city's coat-of-arms, thereby adding depth and rendering them bolder and more visible to incoming visitors to the city.



CUSTOM ENGRAVINGS AND CARVINGS IN CLAY

— The dimension of custom work at Atelier Vierkant is not only confined to shape, colour and texture: it includes also a refined work of engraving. In this way, suggestive phrases and elegant logos and letters are carved permanently in the clay, allowing the utmost personalization of objects and creating the strongest bond between our products and the meaning that people attach to them. From evocative words engraved in pebbles, to exclusive logo carvings in the pots of an elegant beach club up to refined miniatures performed on massive clay roundabouts, the hand-crafted inscriptions and engravings amplify volumes and the play of light and shadow on the clay surface. The tailored engravings, both coloured and not, are performed

at the Atelier by the hand of Stéphanie Busard, who deploys all her creativity and knowhow in order to match each commissioned work to the project's aim and philosophy.



Custom and on demand *Clay* projects





MRB

The low cylindrical MRB series, designed as a low sized planter, comes in different earthy tones. Its shape recalls the traditional shapes of the round conic planters once produced in the area of Breda, Catalogne.

	a	b	h	w
MRB30	37,5cm	28cm	27,5cm	15kg
MRB35	54,5cm	43,5cm	35cm	30kg
MRB30	14,76"	11,02"	10,83"	33lbs
MRB35	21,46"	17,13"	13,78"	66lbs

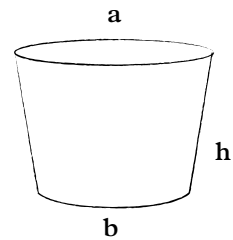



MRA55

MRA45

MRB30

MRB35



V8/NG

ZN27

V8 + GLAZE BOTTOM

MRO

	a	b	h	w
MRO50	36,5cm	27cm	48cm	25kg
MRO55	43,5cm	33,5cm	54cm	30kg
MRO50	14,37"	10,63"	18,90"	55lbs
MRO55	17,13"	13,19"	21,26"	66lbs

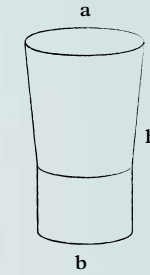

G/BR24

W/BR24

A variation on this is **MRO** series – which have a formal opening on top, and come in a duotone finish.



MRR

	a	b	h	w
MRR65	49cm	34cm	65cm	30kg
MRR80*	57cm	40cm	76cm	50kg
MRR90	80cm	56cm	90cm	110kg
MRR130	115cm	85cm	130cm	250kg
MRR65	19,3"	13,4"	25,6"	66lbs
MRR80*	22,4"	15,7"	29,9"	110lbs
MRR90	31,5"	22"	35,4"	245lbs
MRR130	45,3"	33,5"	51,2"	550lbs

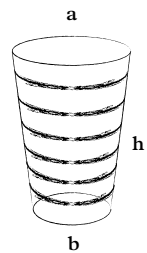

* Suitable for a polyester innerliner.

MU

	a	b	h	w
MU80	40cm	29cm	80cm	40kg
MU100	49cm	40cm	100cm	70kg
MU120	52cm	40cm	120cm	85kg
MU80	15,7"	11,4"	31,5"	88lbs
MU100	19,3"	15,7"	39,4"	155lbs
MU120	20,4"	15,7"	47,2"	190lbs

All MU models are suitable for a polyester innerliner.

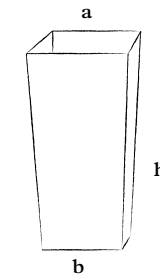

MUR100
at Westfield Village
on Topanga,
Woodland Hills, CA



MUR

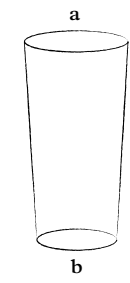

	a	b	h	w
MUR80	44cm	32cm	80cm	35kg
MUR100	55cm	40cm	100cm	65kg
MUR120	58cm	45cm	117cm	75kg
MUR80	17,3"	12,6"	31,5"	65lbs
MUR100	21,6"	15,7"	39,4"	145lbs
MUR120	22,8"	17,7"	46"	165lbs



O



	a	b	c	d	e	h	w	m ³
O60	60cm	22cm	60cm	55cm	49cm	31cm	30kg	34,4l
O75	72cm	24cm	70cm	67cm	60cm	33cm	48kg	60,5l
O90	92cm	36cm	89cm	86cm	71cm	44cm	60kg	112l
O105	113cm	45cm	107cm	107cm	86cm	55cm	85kg	240,2l
O120	120cm	60cm	111cm	108cm	90cm	65cm	100kg	405l
O150	145cm	71cm	135cm	138cm	107cm	72cm	150kg	542,4l
O165	172cm	80cm	158cm	161cm	128cm	92cm	200kg	895l
O60	23,6"	8,7"	23,6"	21,7"	19,3"	12,2"	66lbs	9gal
O75	28,3"	9,4"	27,6"	26,4"	23,6"	13"	105lbs	16gal
O90	36,2"	14,2"	35"	33,9"	28"	17,3"	132lbs	29,6gal
O105	44,5"	17,7"	42,1"	42,1"	33,9"	21,7"	187lbs	63,5gal
O120	47,2"	23,6"	43,7"	42,5"	35,4"	25,6"	220lbs	107gal
O150	57,1"	28"	53,1"	54,3"	42,1"	28,3"	330lbs	143,2gal
O165	67,7"	31,5"	62,2"	63,4"	50,4"	36,2"	440lbs	236,4gal

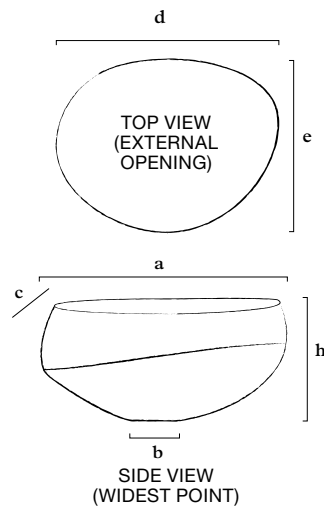

O90





O120

This neoclassic house, built in 1769, is located in the heart of Tielt. The owners consulted Bluet to arrange different settings of plantations that create a scene. Florist Daniël Deprez brought in the **O105**, planted a in white beige clay finish with *Moringa oleifera* (Miracle tree).

O105



OCT

	a	b	h	w
OCT/A21	80cm	66cm	21cm	45kg
OCT/A36	80cm	66cm	36cm	60kg
OCT/A45	80cm	66cm	45cm	75kg
OCT/A21	31,5"	26"	8,3"	99lbs
OCT/A36	31,5"	26"	14,2"	132lbs
OCT/A45	31,5"	26"	17,7"	165lbs

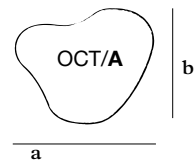

	a	b	h	w
OCT/B21	88cm	71cm	21cm	45kg
OCT/B36	88cm	71cm	36cm	60kg
OCT/B45	88cm	71cm	45cm	75kg
OCT/B21	34,6"	28"	8,3"	99lbs
OCT/B36	34,6"	28"	14,2"	132lbs
OCT/B45	34,6"	28"	17,7"	165lbs

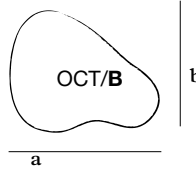

	a	b	h	w
OCT/C21	90cm	56cm	21cm	45kg
OCT/C36	90cm	56cm	36cm	60kg
OCT/C45	90cm	56cm	45cm	75kg
OCT/C21	35,4"	22"	8,3"	99lbs
OCT/C36	35,4"	22"	14,2"	132lbs
OCT/C45	35,4"	22"	17,7"	165lbs

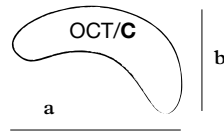

	a	b	h	w
OCT/D21	100cm	55cm	21cm	55kg
OCT/D36	100cm	55cm	36cm	40kg
OCT/D45	100cm	55cm	45cm	85kg
OCT/D21	39,4"	21,7"	8,3"	121lbs
OCT/D36	39,4"	21,7"	14,2"	154lbs
OCT/D45	39,4"	21,7"	17,7"	187lbs

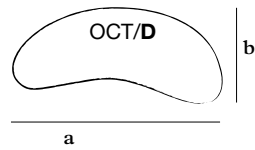



OCT

OCT/C



Barilla Center,
Parma

OD ODB



Possibility
with or without
colour rim.



	a	h	w	m ³
OD40	40cm	45cm	35kg	55l
OD50	50cm	53cm	40kg	105l
OD55	55cm	60cm	50kg	185l
OD60	60cm	72cm	60kg	252l

OD40	15,7"	17,7"	77lbs	14,5gal
OD50	19,7"	20,9"	88lbs	27,7gal
OD55	21,7"	23,6"	110lbs	48,8gal
OD60	23,6"	28,3"	132lbs	66,5gal

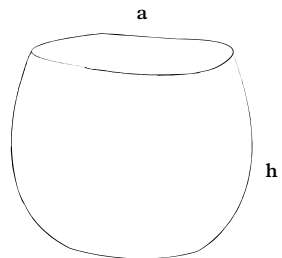



OV60



OD60

Rechts van de Kerk,
Meigem

OD60



OD60



OD60 black
with T1 texture

Since 2018, with the renovation of Rue Mstislav Rostropovitch near the Batignoles quarter in Paris's 17th arrondissement, residential buildings and company headquarters have been built. These make up a new eco-district to which Place des Fleurs has contributed multiple times, in the development of gardens of co-owned properties but above all for balconies and terraces, with 180-degree views running along the Montmartre hill to the Eiffel Tower.



OD

OD60

ODB60



OD60 grey and **ODB60** cork
with nordic white rim

OE

OE80, and OE60
at entrance Atlas Copco,
Boom



	a	h	w	m ³
OE40	44cm	37cm	35kg	45l
OE60	56cm	55cm	50kg	115l
OE70	72cm	64,5cm	75kg	190l
OE80	76cm	73cm	100kg	250l
OE100	96cm	91cm	150kg	565l
OE120	116cm	114cm	250kg	895l
OE40	17,3"	14,6"	77lbs	11,9gal
OE60	22"	21,7"	110lbs	30,4gal
OE70	28,3"	25,4"	165lbs	50,2gal
OE80	29,9"	28,7"	220lbs	66gal
OE100	37,8"	35,8"	330lbs	149,3gal
OE120	45,7"	44,9"	550lbs	236,4gal

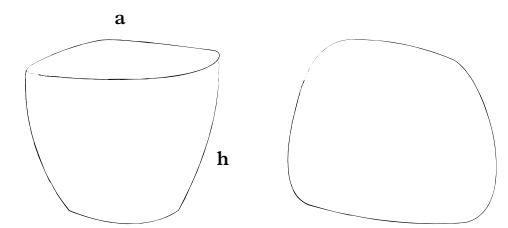

TOP VIEW



集絲坊

OE80 and OE60 in grey
Jisifang Silk Boutique,
Shanghai

OE

OE60 and OE80
planted with
Sedum, *Echeveria glauca*,
Griptoveria titubans,
Lewisia, private Project,
Santiago de Chile.

OE





OE80 in nordic white
with texture T6 at Paya Lebar
office project, Singapore

OE

OF90
at Pastorale,
Reet



OF

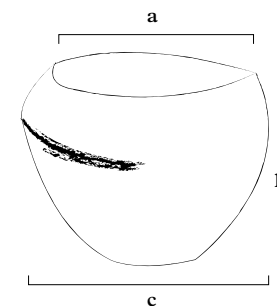

	a	c	h	w	m ³
OF50	30cm	45cm	48cm	30kg	65l
OF70	60cm	75cm	65cm	50kg	156l
OF80	73cm	90cm	80cm	75kg	265l
OF90	85cm	105cm	85cm	100kg	369l
OF110	110cm	125cm	101cm	150kg	735,2l
OF120	120cm	130cm	111cm	200kg	1150l
OF50	19,7"	17,7"	18,9"	66lbs	17,2gal
OF70	23,6"	29,5"	25,6"	110lbs	41,2gal
OF80	28,7"	35,4"	31,5"	165lbs	70gal
OF90	33,5"	41,3"	33,5"	220lbs	97,5gal
OF110	46,1"	49,2"	39,8"	330lbs	194,2gal
OF120	50"	51,2"	43,7"	440lbs	303,7gal

OF

Aripaev, Tallinn







OP

	a	b	h	w
OP40	36cm	29,5cm	38cm	19kg
OP40	14,2"	11,6"	15"	42lbs

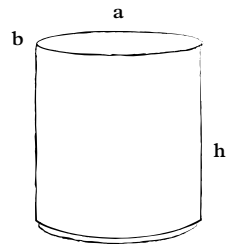

OPTION 1

OPTION 2

OV

	a	h	w	m ³
OV60	55cm	18cm	20kg	20l
OV90	88cm	22cm	35kg	65l
OV60	21,6"	7,1"	45lbs	5,3gal
OV90	34,6"	8,6"	77lbs	17,2gal

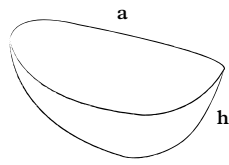

PB

	a	h	w
PB60	60cm	10cm	20kg
PB60	23,6"	3,9"	44lbs

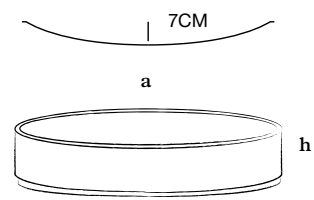

PB is not suitable for outside use during frost.



PL

	a	h	w
PL60	60cm	10,5cm	25kg
PL80	80cm	14cm	35kg
PLU60	60cm	10,5cm	25kg
PLU80	80cm	14cm	35kg

PL60	23,6"	4,1"	55lbs
PL80	31,5"	5,5"	77lbs
PLU60	23,6"	4,1"	55lbs
PLU80	31,5"	5,5"	77lbs

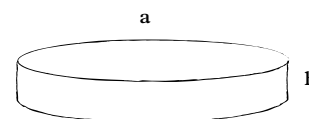

*PL is an open vase.
PLU is a pedestal.*



PL80

GREEN WISE 111 PROJECT

2014.11/8 Tue - 13 Sun

PL

PL80-PLU80
at Private project,
Marbella.



PT



OPTION 1

OPTION 2

	a	b	c	d	h	w
PT60	59cm	62cm	35cm	57cm	19,5cm	38kg
PT70	70cm	72cm	45cm	67cm	19cm	52kg
PT60	23,2"	24,4"	13,8"	22,4"	7,7"	84lbs
PT70	27,6"	28,3"	17,7"	26,4"	7,5"	115lbs

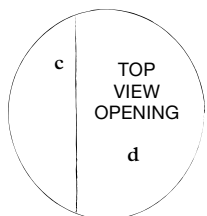
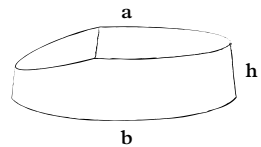

OPTION 2

OPTION 1

OPTION 3



OPTION 3

W26

BL7

RR

	a	b	h	w
RR55*	53cm	32cm	45cm	25kg
RR65	65cm	39cm	55cm	35kg
RR80	75cm	46cm	64cm	50kg
RR100	98cm	58cm	82cm	80kg
RR120	115cm	64cm	95cm	125kg
RR150*	150cm	90cm	130cm	250kg
RRL55*	57cm	42cm	26cm	15kg
RR55*	20,8"	12,6"	17,7"	55lbs
RR65	25,6"	15,3"	21,7"	77lbs
RR80	29,5"	18,1"	25,2"	110lbs
RR100	38,6"	22,8"	32,2"	175lbs
RR120	45,3"	25,2"	37,4"	275lbs
RR150*	59,1"	35,4"	51,1"	550lbs
RRL55*	22,4"	16,5"	10,2"	35lbs

*Items with a *
have a sharp rim (left),
instead of round (above).*

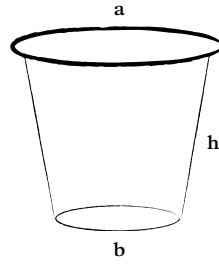

RR





RR120

RR100

RRH

	a	b	h	w
RRH55*	43cm	22cm	55cm	20kg
RRH65	54cm	31cm	65cm	35kg
RRH80	64cm	38cm	78cm	50kg
RRH100	83cm	48cm	100cm	85kg
RRH120	100cm	60cm	120cm	125kg

RRH55*	16,9"	8,6"	21,6"	45lbs
RRH65	21,3"	12,2"	25,6"	77lbs
RRH80	25,2"	15"	30,7"	110lbs
RRH100	32,7"	18,9"	39,4"	190lbs
RRH120	39,4"	23,6"	47,2"	275lbs

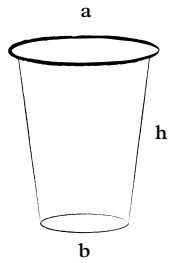

*Items with a *
have a sharp rim
instead of round.*

RRH100 white
Private terrace,
Mexico City



RB

RBC

	a	h	w
RB5060	50cm	60cm	60kg
RBC5060	50cm	60cm	75kg
RB5060	19,7"	23,6"	132lbs
RBC5060	19,7"	23,6"	165lbs

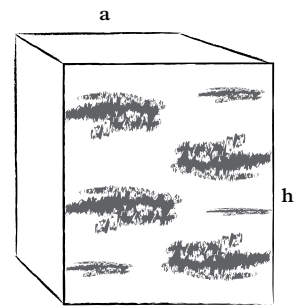

*RB is an open vase.
RBC is a closed pedestal.*



The geometric pattern created by the vertical and horizontal rims and contour is recalled by a dimensional, squared customized bench in clay, based on the **RBC** model and placed at the center of one of the courtyards that embellish the hotel. The overall linearity of the environment is broken and softened by the slender shape of verdant and fawn Japanese Maple *Acer amoenum* cv. *Sanguineum* at the centre of the bench surrounded by Crape myrtle *Lagerstroemia indica* L., giving a sense of height.



RVB

Design
Roel Vandebek

	a	b	h	w
RVB30	31cm	31cm	55cm	16kg
RVB45	45cm	45cm	65cm	30kg
RVB50	51cm	31cm	55cm	25kg

RVB30	12,2"	12,2"	21,7"	35lbs
RVB45	17,7"	17,7"	25,6"	66lbs
RVB50	20,1"	12,2"	21,7"	55lbs

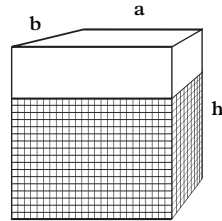

Belgian product designer, *Roel Vandebek*, examines and works on the intersection of design and architecture. Surrounded daily by architects in his studio collective near Maastricht, he is confronted with their continuous requests and challenges. In the research of adaptable and portable pots, Atelier Vierkant and Roel Vandebek decided to cooperate, combining their shared interests. As part of the 2021 collection, Roel presents an innovative series of planters, half wire, half clay. Lightweight, these planters are easily moved around and therefore particularly convenient for apartments, limited sized spaces or anywhere with a specific need for flexibility. The transparency of the wire leaves room for light to shine through, provides airiness and spaciousness to an extent where even the ground underneath the pot is taken into consideration.



RVC

Design
Roel Vandebeek

	a	h	w
RVC40	40,5cm	65cm	28kg
RVC60	56cm	55cm	30kg
RVC40	15,9"	25,6"	62lbs
RVC60	22"	21,7"	66lbs

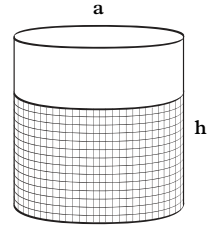

RZ

	a	b	h	w
RZ45	42cm	30cm	45cm	25kg
RZ60	53cm	35cm	60cm	40kg
RZ70	65cm	41cm	70cm	60kg
RZ80	74cm	50cm	80cm	90kg
RZ90	82cm	54cm	90cm	125kg
RZ120	107cm	75cm	120cm	200kg

RZ45	16,5"	11,8"	17,7"	55lbs
RZ60	20,9"	13,8"	23,6"	88lbs
RZ70	25,6"	16,1"	27,5"	135lbs
RZ80	29,1"	19,7"	31,5"	200lbs
RZ90	32,3"	21,2"	35,4"	275lbs
RZ120	42,1"	29,5"	47,2"	440lbs

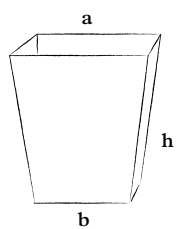

RZ120
in a private project,
Malibu, CA



T14/BL1

RZ60

SB15

	a	h	w
SB15	82cm	16cm	30kg
SB15	32,3"	6,3"	66lbs

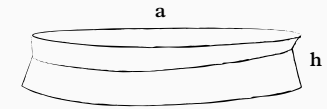

W17/GLAZE



W/W17/GLAZE



SB30
Kåseholm Slott,
Sweden

SB30

	a	h	w	m ³
SB30	80cm	29cm	55kg	95l
<i>SB30</i>	31,5"	11,4"	121lbs	25,1gal

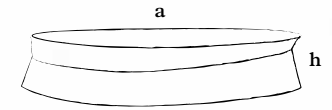

SB15



BR24/W/GLAZE

	a	h	w
SB45	48cm	14,5cm	16kg
SB45	18,9"	5,7"	35lbs

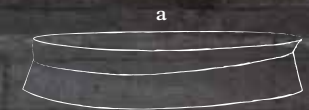

SB45



OPTION 4

OPTION 3

OPTION 1

OPTION 2

SB45



OPTION 2



OPTION 4

SD

*Different line
colour combinations
are possible.*

Info upon request.

*Not suitable
for outside
during frost.*



WHITE

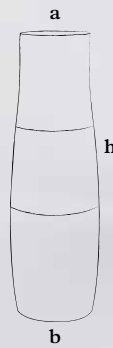

W/WW

BLACK

	a	b	h	w
SD90	23cm	26cm	90cm	30kg
SD130	32cm	38cm	130cm	60kg
SD90	9"	10,4"	35,4"	66lbs
SD130	12,6"	15"	51,2"	132lbs

SDO

	a	b	h	w
SDO80	32cm	46cm	81cm	45kg
SDO90	27cm	38cm	91cm	50kg
SDO80	12,6"	18,1"	31,9"	99lbs
SDO90	10,6"	14,9"	35,8"	110lbs





SJ

	a	h	w
SJ30	80cm	31cm	50kg
SJ40	80cm	43cm	65kg
<i>SJ30</i>	31,5"	12,2"	110lbs
<i>SJ40</i>	31,5"	16,9"	143lbs

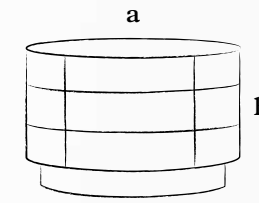

SK

	a	b	h	w
SK40	42cm	2,5cm	7cm	8kg
SD90	16,5"	1"	2,6"	18lbs

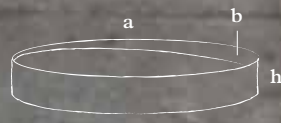

OPTION 1



OPTION 3



OPTION 2



OPTION 5



OPTION 4





SP

	a	b	c	h	w
SP40	35,5cm	30cm	55,5cm	39,5cm	40kg
SP45	27,5cm	17cm	40cm	43cm	20kg
SP50	31,5cm	30cm	54,5cm	45,5cm	45kg
SP80	78cm	66cm	125cm	79cm	65kg
SP100	99cm	66cm	122cm	48cm	75kg
SP40	13,98"	11,81"	21,85"	15,55"	88lbs
SP45	10,83"	6,69"	15,75"	16,93"	44lbs
SP50	12,40"	11,81"	21,46"	17,91"	99lbs
SP80	30,7"	26"	49,2"	31,1"	143lbs
SP100	39"	26"	48"	18,9"	165lbs

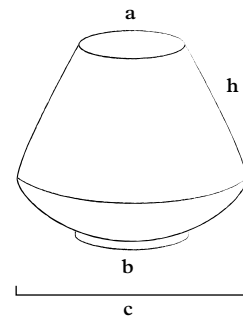

SP50/BL1 + GLAZE

The introduction of engobe surface finishes, and the option to apply the '*Clay Perfumes*' to a big variety of models, broadened the ways the Atelier could express the different natures of clay.

The launch of the **SP** vase — that comes with a two-directional texture and an emerald green or admiral blue colour finish. Originally designed as a flowerpot, they can be used without plantation, as iconic object, or filled up with dry leaves or branches.



SP50/BL1
+ GLAZE



SP



SP50 / BL1 + GLAZE

SP50 / V9 + GLAZE

Clay, my
connection to
the world —
Products for
a lifetime
made by
happy people



Atelier Vierkant Team

— *Francisco* moved from Tenerife to Belgium 7 years ago and he has been working as an artisan at Atelier Vierkant since then. Energetic and positive even early in the morning, he starts telling me his daily life. Every morning his alarm rings at 6 am, when he wakes up and prepares the breakfast for all his family. «By 7.15 I drive with my car to Bruges, where I pick up some of my colleagues. Starting a day in company is always good: we have nice talks in the car, we listen to the radio ...». Once arrived at the Atelier, the daily routine starts: first check to the drying room at 8 o'clock, and then, hands in clay, molding pots. «After the working day Francisco takes the colleagues back to Bruges and goes straight back home «to my family». «Coming home is always another good part of the day, because it allows you to stay with your family, to share our stories and to tell each other our day. Of course, also family time requires a tight schedule to respect: bringing my daughter to ballet and music classes and driving her back home afterwards...»

— Besides working life and family time, cultivating his own passions and hobbies and finding time to dedicate to them is crucial. In fact, having a healthy balance between work, family and free time is a fundamental aspect to take into consideration. That is why Francisco does not renounce to his hobbies, trying to fit them in his already very busy agenda. «My hobby is playing volleyball. Even if it's tiring, I believe that it is important to cultivate your passions and to find time for yourself and for what you like. That is why during the weekend my family and I organize activities to do all together, enjoying some calm before the beginning of the week».

Clay, my connection to the world ...



— While talking about his time at Ateleir Vierkant, Francisco takes a look at the production plants visible from the office where we are having a chat and recalls his first days at Atelier Vierkant. «When I started working with clay, it was a totally new element for me and establishing a feeling with was not an easy job. I remember Willy came to me and said that in order to understand clay I had to feel my actions from inside, I had to feel what my hands were doing when they were busy in the clay. At the first moment, I didn't really get what he meant, but two years later I started realizing that the only way a pot can be made is through your intuition». In fact, the natural origin of clay does not allow the existence of neither a perfect formula nor a fixed rule to make the perfect pot: the best way is to feel with your senses and to adjust the way of working accordingly. «This is what I like of clay, that it is a relationship that refines and improves with time. The more you know about it, the more it feels natural and innate to you to work with it».

— There are several aspects that can be appreciated of his job, among which the most important is the sense of responsibility concerning everyone's tasks and his duties. «What I really appreciate is the fact is that responsibility allows you to be flexible: the presence of a precise task to achieve allows you to adjust and to organize your schedule according to your needs, managing time in the way it fits for you. I think it is a good method to achieve good results and to keep a proactive attitude towards what you do». Of course, sometimes there are challenges to go through: «Sometimes it's difficult to look after all the responsibilities you have at once: you're always too busy! That is why organization and good communication among colleagues is crucial in order to achieve the results expected and to ensure excellent coordination».

Clay, my connection to the world ...



— *Inge* is one of the team leaders working in the Atelier, with her hands in clay every day. She lives in Oostende with her family. Everyday she wakes up at 6.40 and, after a quick breakfast with her family she is ready to go to work. «I'm not a morning person, so I always have to count the minutes to manage to do everything». Inge's everyday routine in the atelier starts at 8 and ends at 4.30. During the time she and her colleagues work with dedication creating pots of impressive shapes, lively colours and unique textures. After work, she goes to pick up her kids, ready to start her family routine. «Family time as well implies a tight schedule to respect and sometimes aligning everyone's hobbies and programs can be challenging. It is true that during the week it is not easy to manage everyone's duties. during the weekend, however, I enjoy staying with my family, spending time together and sharing as many experiences. We always organize something fun to do together, whether it could be going to the cinema, to the swimming pool or just simply strolling around the city».

— *Inge* has been working at Atelier Vierkant for three years and half and now she is one of Atelier Vierkant's team leader. «Being team leader means that I have to keep an eye on how pots are made and to monitor the pace and the results of the team's general work: working together as a team implies having good organization and receiving mutual support. In this way, we help each other and we make sure that everybody is involved in the activity of overview, so that monitoring the progress of the work becomes an activity from which everyone can learn and take benefits». Of course, organization and communication with the colleagues is sometimes challenging, especially the coordination with the other different teams working in the Atelier, «but we do our best to cooperate in a stimulating and productive way».

Clay, my connection to the world ...



— *Inge's* approach to clay involves the therapeutic powers of the material and the sense of peace and reconnection with nature that clay is able to convey. «I like working with clay because it makes me feel decompressed. Everyday life at the Atelier is really busy, but I never feel stressed. I like the atmosphere we breathe here, inspiration hides at every corner and it seems to work in a big creative thinktank: I like to see what I produced, from scratches to the end. When I see one of our gigantic pots around the world I can say that I made it with my hands, and this is very satisfying».

— *Jotam* lives in a small town close to Oostende. «I used to live in Oostende, but my family and I decided to move to a calmer and smaller town: closer to nature, it is also a good environment for our kids. Every day I wake up at 6.30, get myself and one of my kids ready while my girlfriend prepares the other one». After a quick breakfast Jotam rushes to work around 7.40 and, when he leaves the Atelier in the afternoon, he goes straight back to home and prepares the supper for everyone. «One of my passion is cooking, especially when I prepare something good for the people I love». Playing games his kids or watching TV with all-together account also for what Jotam enjoys the most when he is at home and has, finally, some free time. «We usually put the children to bed early —or at least that is what we try to do— and my typical weekly day ends at 23. Besides cooking, I like training and doing fitness. I try to exercise as much as possible according to my family and to my working schedule». After a busy week, weekend to visit my relatives and stay with my family».

Clay, my connection to the world ...

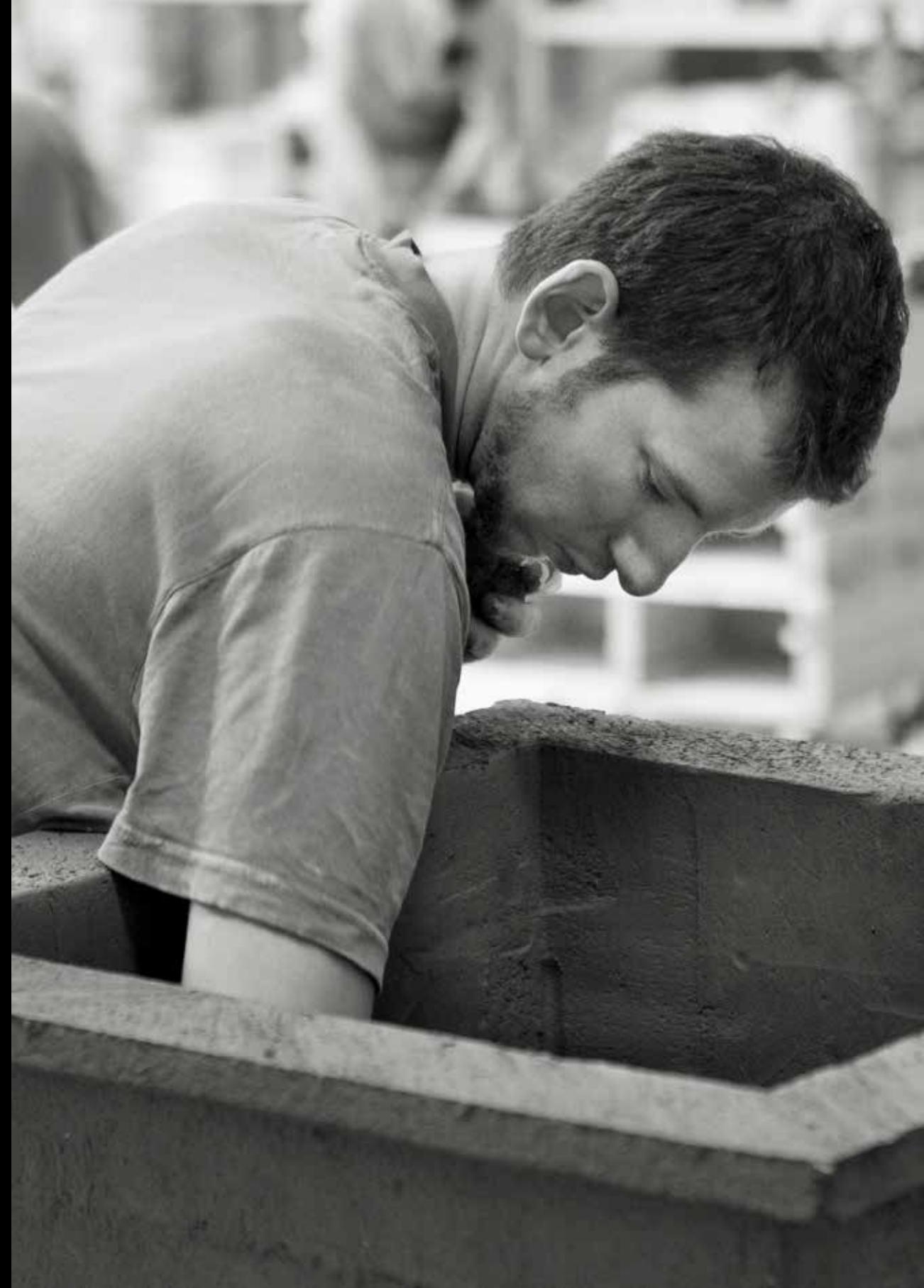

— *Jotam* has been working at Atelier Vierkant for almost 5 years. «What I like of my job is the satisfaction that seeing and touching what you have made with your own hands give me». Besides the sense of rewarding given by seeing the results of artisans' hard work, this accounts also for a helpful strategy to assess everyone's progress and to understand, by seeing directly the vases produced, the weaker skills of each of the artisans, improving their ability and knowhow in an effective and intuitive way. The spirit of cooperation and team work is also a fundamental aspect to take into consideration while talking about Atelier Vierkant's modus operandi. «Sharing the aspects of our daily life and our interests is something natural among colleagues, especially because we have approximately the same age. This helps to know each other better and to create a good team spirit». Another appreciated aspect is the sense of responsibility given in the job. «Given a certain goal, we are able to organize our schedule autonomously». It is also true that the strive to shape clay at his own will, sometimes struggling with it in the actions of cutting, shaping, molding the material, is sometimes physically tiring. «The key for this job is to find a good balance between rest and work and to listen to your body's needs, acting accordingly and leaving it time to fully recover».

— When I ask *Jotam* which aspects of working with clay fascinate him, his voice has no hesitation in telling me that what impresses him is the enormous potential of such a natural and simple material. «I didn't know that I could do such things with clay. When I was a child, my mother used to work with clay, shaping tiny figures and small pots. However, when I started working at Atelier Vierkant, a totally new perspective opened in front of me and I realized that clay has a unique potential that allows you to think big and to act even bigger, making something outstanding – massive pots. Eventually, after the fatigue of molding, shaping and smoothing

Clay, my connection to the world ...



a big amount of raw clay, seeing what you have done with your hands is incredibly satisfying». Atelier Vierkant has, in this perspective, the power of turning an ordinary activity –making pots– in an extraordinary blend of art and craft. «The majority of people think that making vases is something related with small, boring pots. There is no need to say that, once visited the factory, their opinion about pottery is completely reshaped and remolded».

— *Marta* is 26 years old and comes from Poland. At the Atelier, she is responsible for the creation of the many textures decorating Atelier Vierkant pots and vessels. «I moved to Belgium 4 years ago with my husband and I have been working at Atelier Vierkant for almost three years and a half ». Every-day *Marta* wakes up at 6.30 in the morning and after a quick breakfast she is already in the car on the way to pick *Marta*, her colleague, up to go together to the Atelier: hands in clay, finishing structures and textures, her working routine starts. Passion for details and for decorations have always amused *Marta*. «After work I really enjoy dedicating myself to my favourite hobby, which is making handcrafts with paper, such as boxes and greeting cards. After work, she always finds the time to call her parents via Skype and share with them her day. Even though my family lives far away, I met a lot of wonderful people at Atelier Vierkant. Thanks to the constant team work and cooperation, everyone shares his own history and his own ideas. We are different from each other, but it is such difference that makes our team so strong. At the atelier difference and cohesion are what makes me feel like in a small family».

Clay, my connection to the world ...



— When Marta came to Belgium from Poland, clay was something new for her to work with. But as all the new things, she found the art of pottery amusing and fascinating. It is really true that clay somehow reminds us of our roots and heritage, bringing sometimes some sweet memory with it. «It reminds me those moments when, as a child, I used to play with plasticines». Many years later, Marta found herself enjoying the same amusement creating the textures and the structures of the pots and checking if customized items are done properly. «My passion for manual precision works found a new way of expression in clay works. I feel good working with the small rocks in the structure of chamotte, because they ease the creation of many combination of textures. I enjoy modelling its uneven, coarsed composition which makes textures unique, especially in black and red clay». The sense of mutual responsibility given by the constant team work at Atelier Vierkant is also an aspect that enhances collective learning and share of knowhow.

Clay, my connection to the world ...

SO

	a	b	h	w
SO80	81cm	73cm	23cm	25kg
SO80	31,9"	28,7"	9"	55lbs

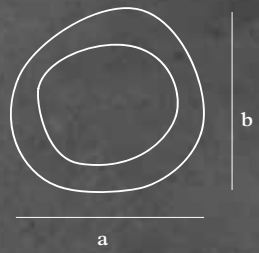



SO in extra white,
planted with
Cyphostemma juttae.

SR

SR is single faced.

	a	b	h	w
SR45	40cm	45cm	9cm	15kg
SR60	50cm	60cm	12cm	20kg
SR75	62cm	75cm	15cm	30kg
SR95	77cm	95cm	19cm	50kg
SR120	100cm	120cm	30cm	125kg
SR150	150cm	150cm	40cm	200kg

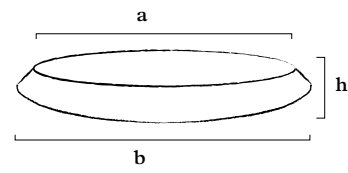

SR45	15,7"	17,7"	3,5"	33lbs
SR60	19,7"	23,6"	4,7"	45lbs
SR75	24,4"	29,5"	5,9"	65lbs
SR95	30,3"	37,4"	7,5"	110lbs
SR120	39,3"	47,2"	11,8"	275lbs
SR150	59,1"	59,1"	15,7"	440lbs





SR

SRD

SRD is double faced.

	a	b	h	w
SRD60	50cm	60cm	12cm	25kg
SRD75	62cm	75cm	15cm	40kg
SRD95	77cm	95cm	19cm	75kg
SRD60	19,7"	23,6"	4,7"	55lbs
SRD75	24,4"	29,5"	5,9"	88lbs
SRD95	30,3"	37,4"	7,5"	165lbs

SR and SRD are not suitable for outside use during frost.

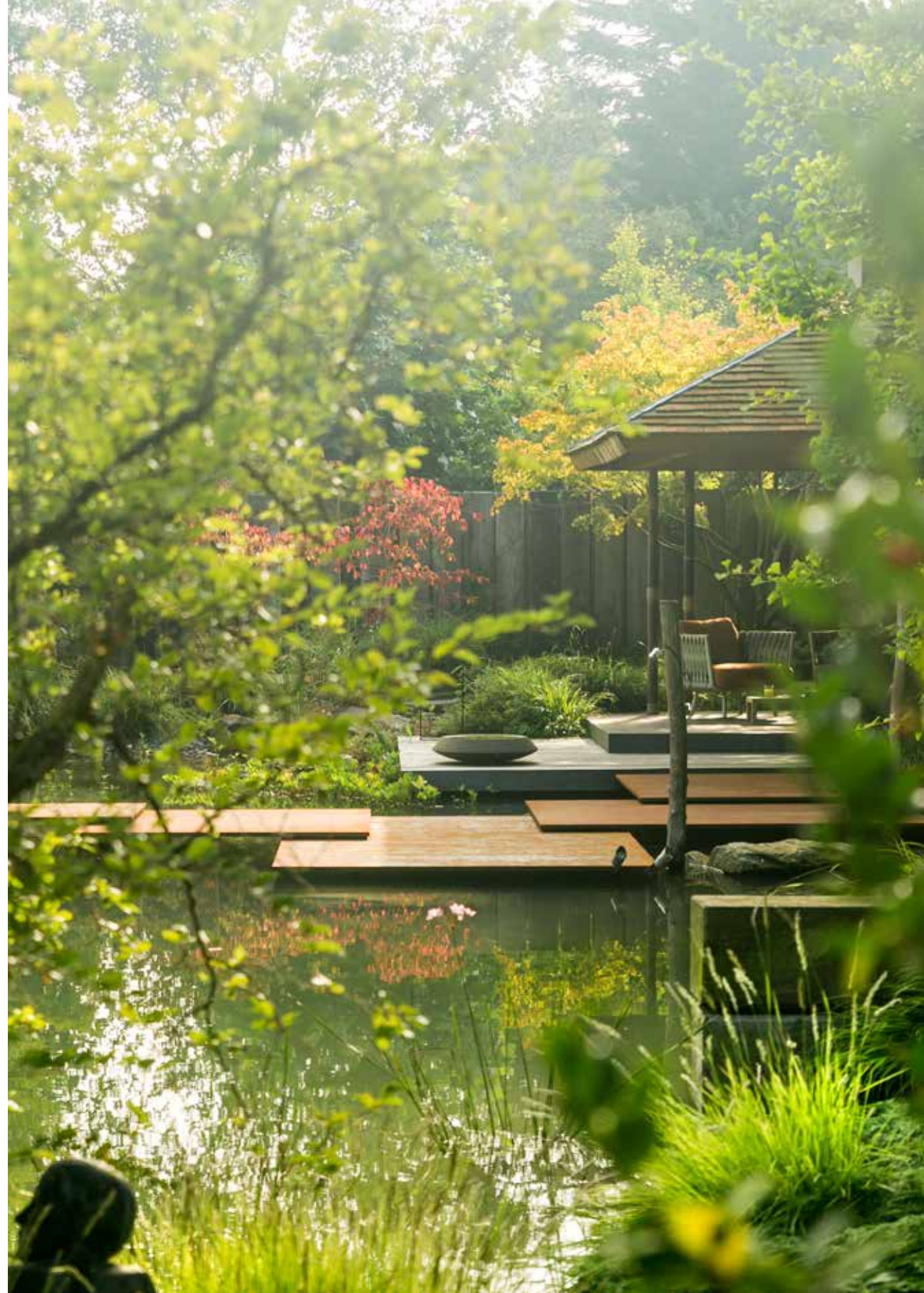



SRD95

SRS

	a	h	w
SRS65	65cm	17cm	25kg
SRS75	75cm	22cm	30kg
SRS95	95cm	30cm	50kg
SRS130	130cm	50cm	150kg
SRS65	25,6"	6,7"	55lbs
SRS75	29,5"	8,7"	66lbs
SRS95	37,4"	11,8"	132lbs
SRS130	51,2"	19,7"	331lbs

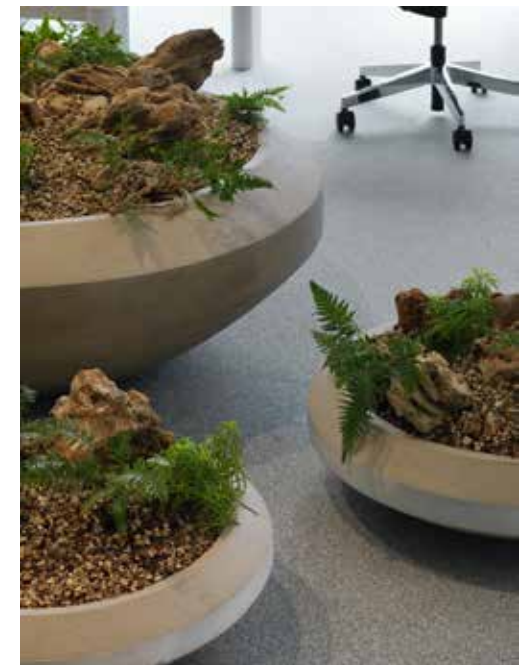
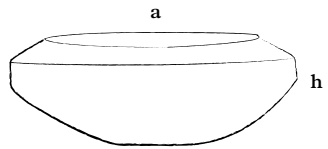



SY SYD

	a	b	h	w
SY70	40cm	22cm	72cm	40kg
SY90	45cm	26cm	83cm	45kg
SYD90	45cm	26cm	83cm	60kg
SY70	15,7"	8,6"	28,3"	88lbs
SY90	17,7"	10,2"	32,7"	100lbs
SYD90	17,7"	10,2"	32,7"	135lbs

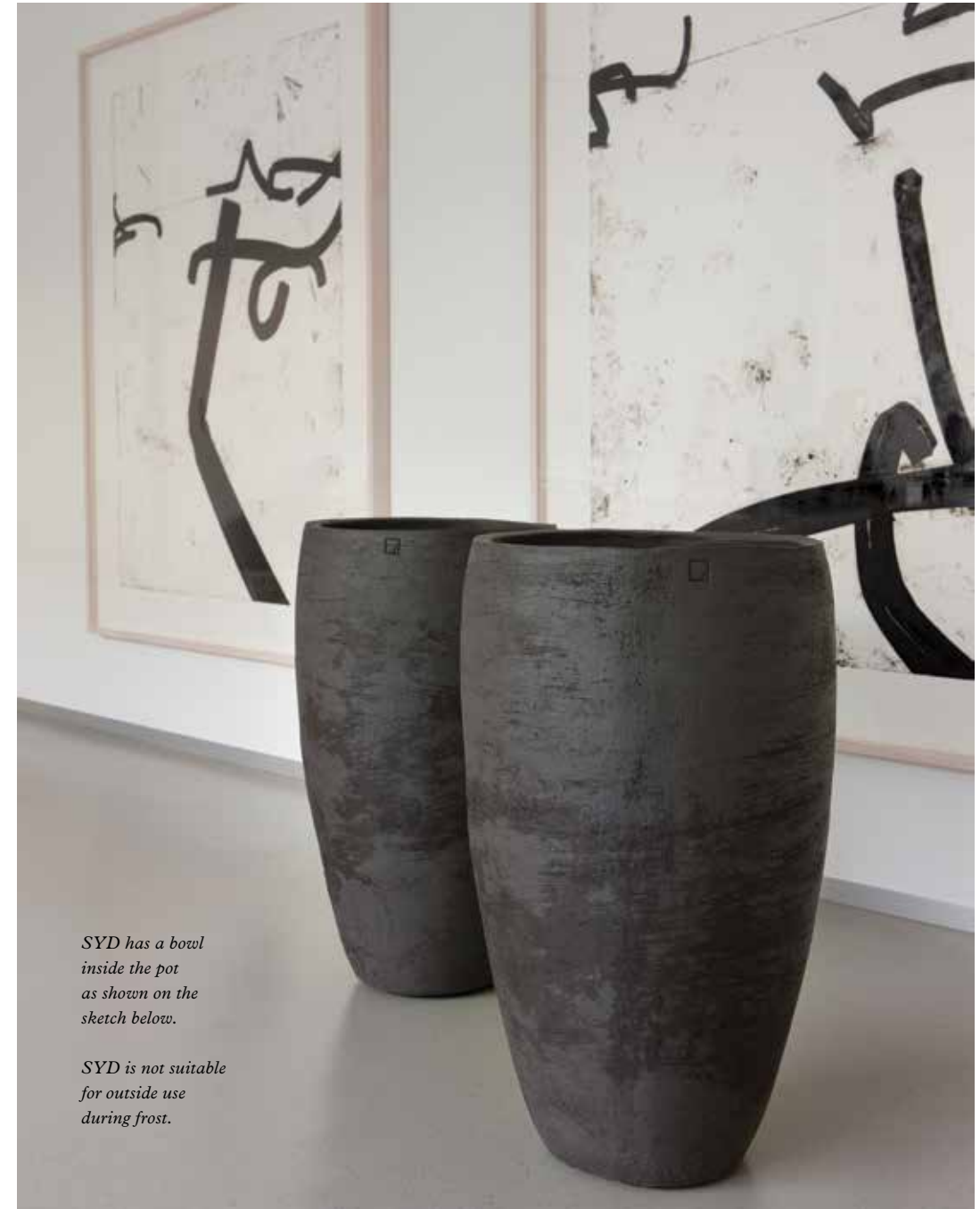
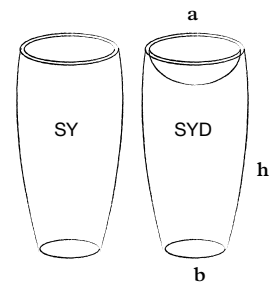

*SYD has a bowl
inside the pot
as shown on the
sketch below.*

*SYD is not suitable
for outside use
during frost.*

TA

	a	b	h	w
TA30	24,5cm	41cm	32,5cm	15kg
TA50	29cm	49cm	45,5cm	25kg
TA30	9,65"	16,14"	12,80"	33lbs
TA50	11,42"	19,29"	17,91"	55lbs

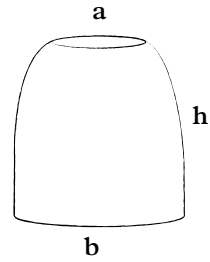

The **TA** series, finished in fine ochre, grey and light blue are examples of how an object assumes its role in the today's interior setting; it not only completes the existing colour palette, but adds texture and volume of shades to the total architectural plan.



TAH

	a	b	h	w
TAH45	20x16,5cm	26,5x20,5cm	45cm	15kg
TAH50	24,5x20cm	33,5x26cm	50cm	20kg
TAH70	28x22cm	36x30cm	73cm	35kg
TAH80	34x28cm	46x40cm	80cm	45kg
<i>TAH45</i>	7,9x6,5"	10,4x8,1"	17,7"	33lbs
<i>TAH50</i>	9,6x7,9"	13,2x10,2"	19,7"	44lbs
<i>TAH70</i>	11x8,6"	14,2x11,8"	28,7"	77,2lbs
<i>TAH80</i>	13,4x11"	18,1x15,7"	31,5"	99,2lbs

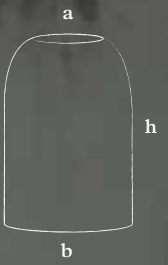

R13

G20

W17

BR24

Y18

TAH



TP

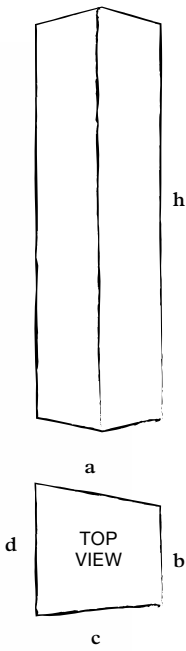

	a	b	c	d	h	w
TP120	37cm	46cm	44cm	50cm	120cm	60kg
TP200	40cm	47cm	50cm	54cm	200cm	300kg
TP120	14,5"	18,1"	17,3"	19,7"	47,2"	132lbs
TP200	15,7"	18,5"	19,7"	21,3"	78,7"	660lbs





TW

	a	b	h	w
TW30	56cm	45cm	33cm	50kg
TW35	47cm	49cm	34cm	45kg
TW40	54cm	53cm	41cm	65kg
TW30	22"	17,7"	13"	110lbs
TW35	18,5"	19,3"	13,4"	99lbs
TW40	21,3"	20,9"	16,1"	143lbs

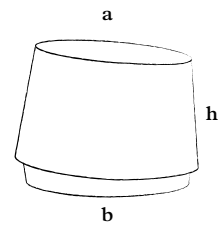

U

	a	b	h	w	m3
U40	40cm	19,5cm	30cm	15kg	18l
U50	50cm	23,5cm	39cm	20kg	40l
U60	60cm	27cm	48cm	35kg	79,4l
U70	70cm	32cm	50cm	50kg	123,5l
U80	78cm	31,5cm	60cm	65kg	140,4l
U90	90cm	41cm	63cm	110kg	248,2l
U100	100cm	45cm	72cm	150kg	365l
U10080	100cm	45cm	78cm	170kg	465l
U12065	120cm	60cm	65cm	200kg	535l
U120	120cm	60cm	90cm	250kg	683,2l
U140	140cm	75cm	96cm	350kg	800l
U160	160cm	96cm	96cm	450kg	1285l
U40	15,7"	76,8"	11,8"	35lbs	4,8gal
U50	19,7"	92,5"	15,3"	45lbs	10,6gal
U60	23,6"	10,6"	18,9"	77lbs	21gal
U70	27,5"	12,6"	19,6"	110lbs	32,6gal
U80	30,7"	124"	23,6"	145lbs	37,1gal
U90	35,4"	16,1"	24,8"	242lbs	65,7gal
U100	39,4"	17,7"	28,3"	330lbs	96,4gal
U10080	39,4"	17,7"	30,7"	374lbs	122,8gal
U12065	47,2"	23,6"	25,6"	440lbs	141,3gal
U120	47,2"	23,6"	35,4"	550lbs	180,5gal
U140	55,1"	29,5"	37,8"	770lbs	211,3gal
U160	62,9"	37,8"	37,8"	990lbs	339,5gal

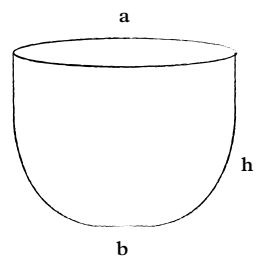

U12065
in grey clay planted with
bonsai pine trees.



U16080 in black,
Swiss Re, Zurich



U





UB

	a	b	h	w	m ³
UB40	40cm	20cm	30cm	15kg	18l
UB50	50cm	25cm	39cm	20kg	40l
UB80	78cm	30cm	68cm	75kg	140,4l
UB40	15,7"	7,9"	11,8"	33lbs	4,8gal
UB50	19,7"	9,8"	15,3"	44lbs	10,6gal
UB80	30,7"	11,8"	26,8"	165lbs	37,1gal



Following bark textures are possible:
 White clay with grey texture
 Grey clay with black texture
 Black clay with red texture
 Red clay with black texture

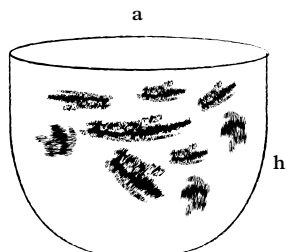

UC

	a	b	h	w
UC50	47cm	57cm	46cm	20kg
UC50	18,5"	22,4"	18,1"	44lbs

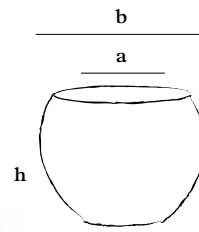

UDS

	a	b	h	w
UDS60	30cm	60cm	9cm	20kg
UDS60	11,8"	23,6"	3,9"	44lbs

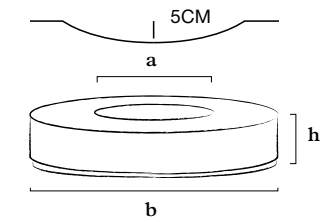

*UDS is not suitable
for outside
use during frost*



UE



G/Z21

	a	h	w	m ³
UE80	78cm	60cm	65kg	140,4l
UE100	100cm	72cm	150kg	365l
UE120	120cm	90cm	250kg	683,2l
UE80	30,7"	23,6"	145lbs	37,1gal
UE100	39,4"	28,3"	330lbs	96,4gal
UE120	47,2"	35,4"	550lbs	180,5gal

Possible colour textures on opposite page.

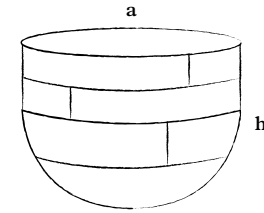

G/Z21



Z/R12



W/G20



Z/R13



G/R12





W/G20

UE

UE120 and **UE80** vessels plantes
with palms. International Market Place,
Honolulu, Hawaii

UF



	a	h	w	m ³
UF60	58cm	44cm	50kg	79,4l
UF80	80cm	60cm	80kg	140,4l
UF100	100cm	68cm	250kg	365l
UF120	120cm	90cm	350kg	683,2l
UF140	140cm	90cm	400kg	800l
UF160	160cm	96cm	500kg	1285l

	a	h	w	m ³
UF60	22,8"	17,3"	110lbs	21gal
UF80	31,5"	23,6"	176lbs	37,1gal
UF100	39,4"	26,8"	551lbs	96,4gal
UF120	47,2"	35,4"	772lbs	180,5gal
UF140	55,1"	35,4"	882lbs	211,3gal
UF160	63"	37,8"	1102lbs	339,5gal

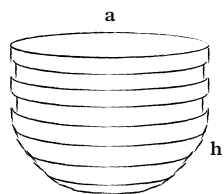

UF120 white,
Turkish Embassy,
Berlin



UF80 white,
Sofia Hotel, Barcelona

UF100 grey,
private residence
Long Island, NY

UF



UF



UF80 grey,
Kempinski
Hotel,
Kitzbühl



UF160 white,
private residences,
Abu Dhabi

UF

UF80



UG

	a	h	w	m ³
UG60	60cm	47cm	35kg	79,4l
<i>UG60</i>	23,6"	18,5"	77lbs	21gal

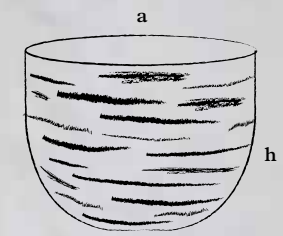

W/G20



UFS

	a	h	w
UFS40	40cm	9cm	15kg
UFS50	50cm	10cm	20kg
UFS60	60cm	12cm	35kg
UFS80	80cm	15cm	50kg
UFS40	15,7"	3,5"	33lbs
UFS50	19,7"	3,9"	44lbs
UFS60	23,6"	4,7"	77lbs
UFS80	31,5"	5,9"	110lbs

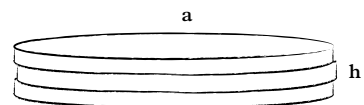

UH vases planted with tender *Pennisetum alop* 'Black Beauty' that contrasts with the grey and white shades of the vases and the whiteness of the wall while simultaneously corresponding to the verdant vine behind it.

UH

	a	h	w
UH80	48cm	72cm	35kg
UH80	18,9"	28,3"	77lbs

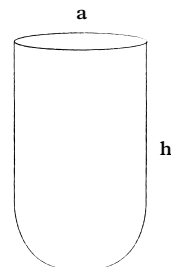

UK

	a	h	w
UK60	60cm	50cm	35kg
UK60	23,6"	19,7"	77lbs

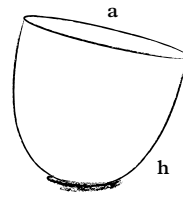

Different colour combinations are possible.

UK is standard delivered with a plexiglass-ring

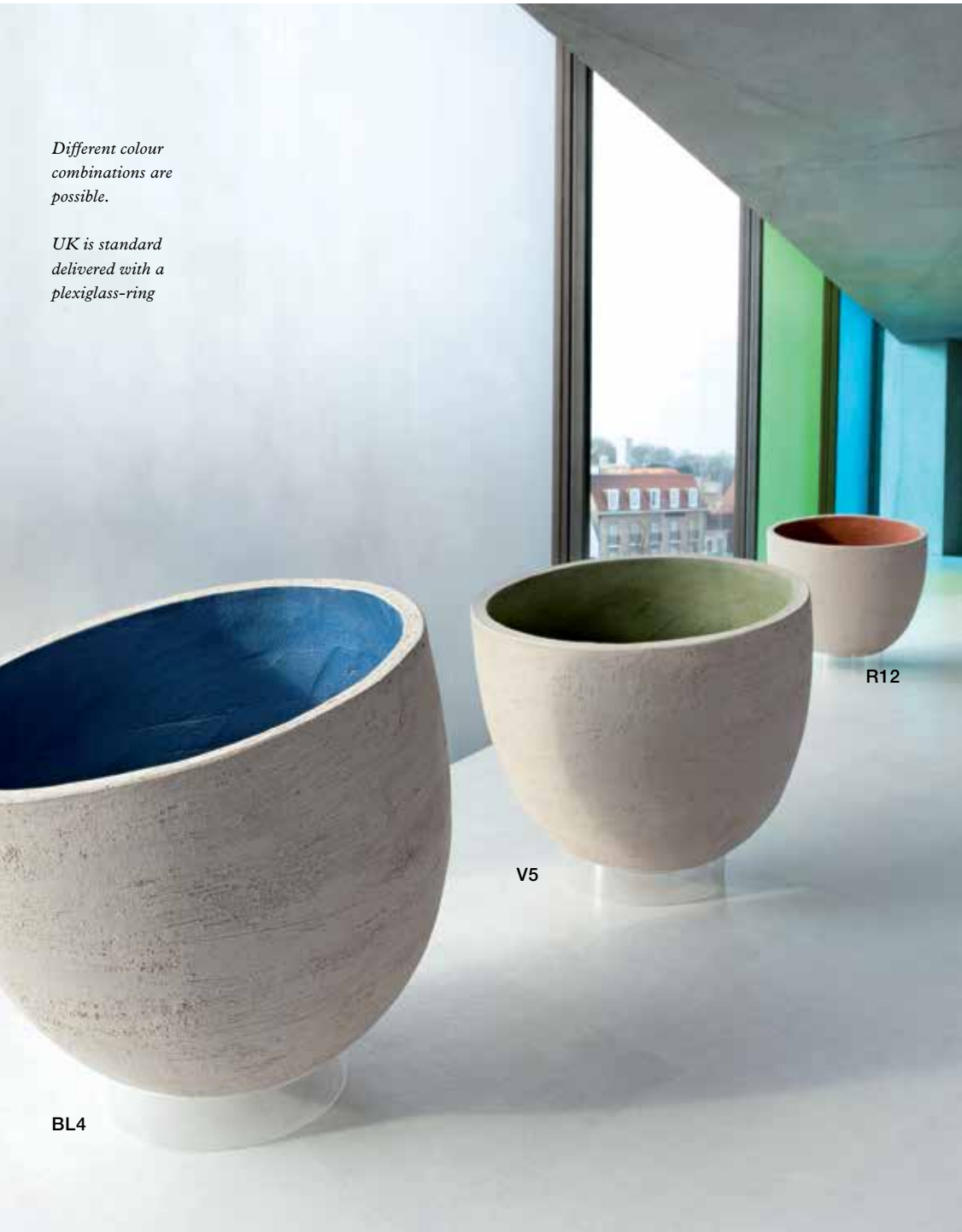

BL4

V5

R12

UK



UK white with red



UKL



	a	h	w
UKL60	67cm	22cm	30kg
UKL60	26,4"	8,6"	65lbs

Different colour combinations are possible.

UKL is standard delivered with a plexiglass-ring

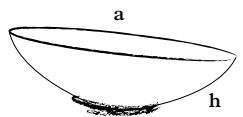

UO



UO80 black,
Fort Beemster.
Design developed
in collaboration
with Osiris Hertman
Studio

	a	b	h	w	m ³
UO80	78cm	30cm	68cm	75kg	140,4l
UO120	120cm	68cm	90cm	350kg	683,2l
UO80	30,7"	11,8"	26,8"	165lbs	37,1gal
UO120	47,2"	26,7"	35,4"	550lbs	180,5gal

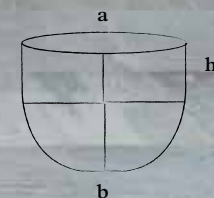



UO

UO80 red and **UO120** black
Lucebert Restaurant,
Tilburg





U080



UM

	a	h	w	m ³
UM80	80cm	60cm	70kg	140,4l
UM100	100cm	72cm	150kg	365l
UM120	120cm	88cm	250kg	683,2l

UM80	31,5"	23,6"	155lbs	37,1gal
UM100	39,4"	28,3"	330lbs	96,4gal
UM120	47,2"	34,6"	550lbs	180,5gal

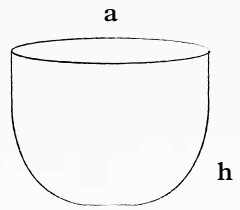

UT

	a	h	w	m ³
UT80	80cm	60cm	70kg	140,4l
UT100	100cm	72cm	150kg	365l
UT120	120cm	88cm	250kg	683,2l

UT80	31,5"	23,6"	155lbs	37,1gal
UT100	39,4"	28,3"	330lbs	96,4gal
UT120	47,2"	34,6"	550lbs	180,5gal

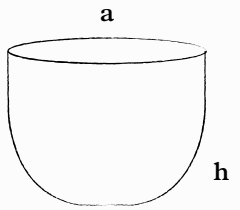

UP

	a	h	w
UP60	60cm	47cm	35kg
UP60	23,6"	18,5"	77lbs

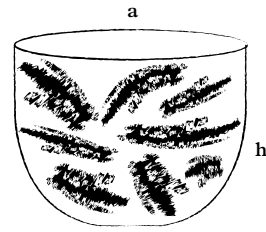

UQ

	a	b	h	w
UQ100	98cm	52cm	78cm	260kg
UQ100	38,6"	20,5"	30,7"	572lbs

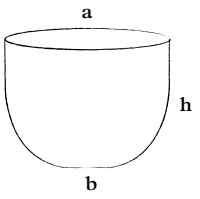

UR

	a	h	w	m ³
UR50	60cm	40cm	30kg	50l
UR60	60cm	50cm	35kg	79,4l
UR70	70cm	50cm	55kg	123,5l
UR80	78cm	60cm	70kg	140,4l
UR90	90cm	68cm	110kg	248,2l
UR100	100cm	72cm	150kg	365l
UR120	120cm	90cm	250kg	683,2l

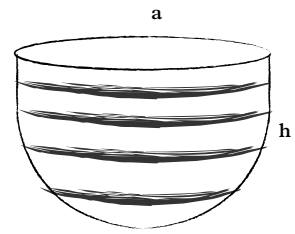

UR50	23,6"	15,7"	55lbs	10,6gal
UR60	23,6"	19,7"	77lbs	21gal
UR70	27,6"	19,7"	121lbs	32,6gal
UR80	30,7"	23,6"	155lbs	37,1gal
UR90	35,4"	26,8"	242lbs	65,7gal
UR100	39,4"	28,3"	330lbs	96,4gal
UR120	47,2"	35,4"	550lbs	180,5gal





Custom **UR8050** white
RHS Chelsea Flower Show,
Andy Sturgeon



UR

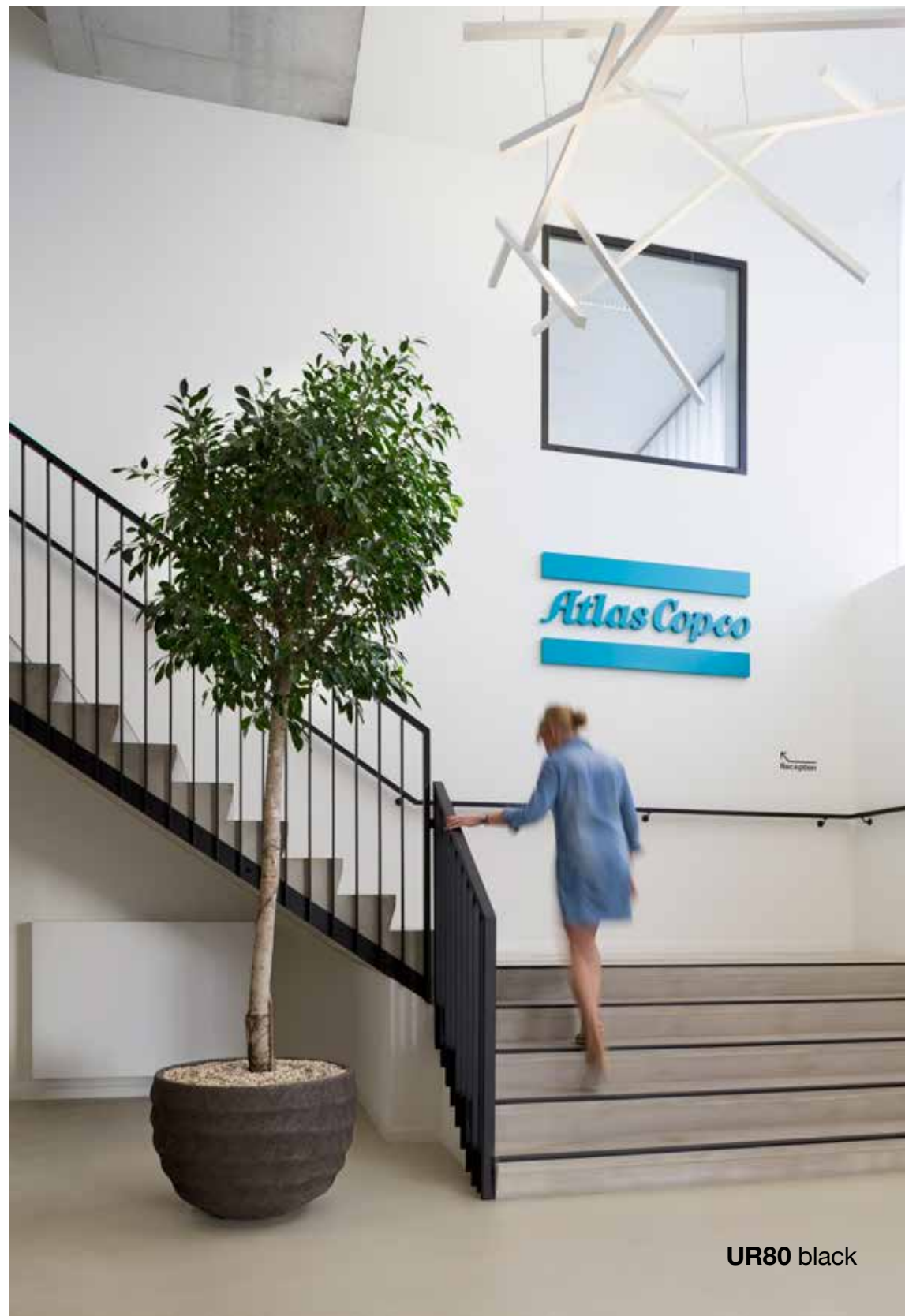

UR80 black

UR



Kåseholm Slott



— On account of the unique experiences provided by the evocative setting of *Kåseholm*, and due to the plenitude of untamed nature that surrounds it, the estate was chosen to host and to present Atelier Vierkant's new collection. These shapes, patterns and colour matches perfectly blend with the renovated indoor and outdoor areas of the estate. The term that best describes the newly created vases is 'experimentation'. New ideas and inspiration have been materialized in the form of colour experimentation, daring shapes and innovative decorative patterns as well as textures. From the long, thin cylindrical shapes of CD and CC models to the cut, oblique lines of FG and the unique shape of CS which vertically combines two different-sized cylinders, Atelier Vierkant's *Kåseholm* collection has a unique impact on the surrounding environment not just by complementing and enriching it but above all by introducing pieces that stand out as masterpieces in the art of pottery. A completely renovated colour palette explores the pastel shades of sage green, pink and light green, creating chromatic combinations that highlight the shapes and the sizes of the new models.

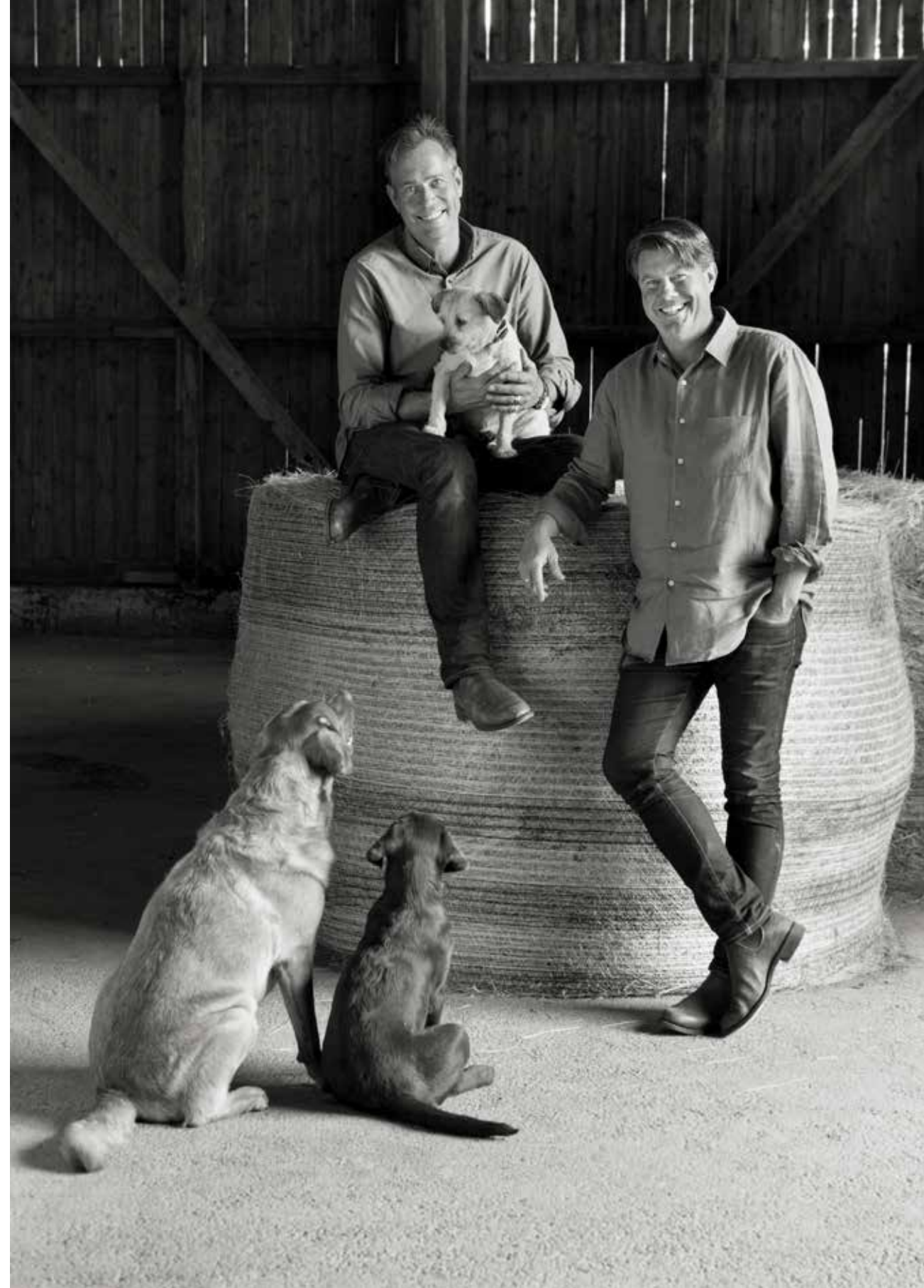



— The extreme versatility of clay is fully seized in the daring shapes of CS, composed by two cylindrical shapes. The smaller form creates a base upon which a larger clay structure is placed. The unusual shape gives pots an enhanced sense of verticality in line with the impressive height of the wooden structure, which used to be a massive haystack warehouse.

— Nonetheless, their overall height is counterbalanced by the pattern of horizontal, regularly-placed severe lines decorating their surface. The intense burgundy, brick red and grey of the colour palette recall the tints of the surrounding wooden structure and of the stone floor, while the tender shades of green and white succeed in creating an evocative chromatic contrast, further enhanced by the alternated stripes of the pattern and the rough horizontality of the texture.

— The three-dimensional sense of volume is fostered by the cylindrical shapes which resemble the soft haystacks of the background. It is also reinforced by the tints seen in the inner-surfaces of the pots, which contrast with the external decorations and accordingly convey an

enhanced sense of depth.

— Experimentation is further pursued in the search for unusual yet harmonic sizes, complemented and highlighted by thoughtful colours and textures. In this perspective, different degrees of thickness have been adapted to the tiny size and rounded lines of CS and CSD in which the pattern of two different overlapping cylindrical shapes is repeated on a smaller scale. The horizontal, striped texture and the neutral yet vivid colours emphasise the volume of the rounded shapes of the model, resulting in the unique accordance with the coexisting classical and modern vibes of Kåseholm.

— Another strong link to the many pieces of art decorating the indoor areas of the manor is produced by the cut-up, broken lines of FG that immediately recall the sloped lines of the modern painting behind them. Nonetheless, the two-dimensional pattern is enriched by the rounded, conical shapes of the vases, giving volume to the area. This particular colour combination partly plays off of a soft chromatic contrast, maintaining its natural artistic continuation while also allowing

the models themselves to stand out as unique pieces of art. More neutral colour combinations in the tints of grey, creme and taupe blend with the colour of the walls and create a contrasting link between the facade and the light brown of the parquet, enhanced by the oblique shapes that break the overall horizontality of the room.

— Cylindrical shapes are used as additional inspiration in the creation of CD model vases. Here, the common theme of experimentation plays a major role in the shape and texture, and a lesser role in the choice of colours. The horizontally stretched cylindrical silhouettes characterising the vases, coupled with the thin slot on the top, allow the natural light to penetrate, creating a scheme of shadows and lights that stresses the depth and plasticity of the clay bodies. This unique and innovative shape is linked to the natural, striped texture of the wooden elements behind it through their shared earthy, yet sophisticated, streaked textures and the grey-ish and brown shades colouring their surfaces.

— The delicate lines of elliptical, sloped CC models provide geometric variation to the

pattern of rhythmic, horizontal lines provided by the floor and the plastered skirting. The delicate colour palette is thought to provide a strong hint at the tints of the modern picture on the wall, thus blending harmoniously with its lines and colours.

— The journey in shape and colour experimentation continues with the D series vases, which deploy their potential in their striped pattern and one-of-a-kind shape. The combination of tints is meant to create a narrative that links the vases both to the renovated style and to the refined colours of the manor and of the surrounding natural environment where sage green, grey and shades of brown can be found in the rocks, fields, and trees. In this perspective, natural tints and sophisticated patterns intermingle to enhance the unique D-shape of the vases.



US

	a	h	w	m ³
US60	58cm	44cm	35kg	79,4l
US70	70cm	50cm	55kg	123,5l
US80	78cm	68cm	65kg	140,4l
US90	90cm	68cm	110kg	248,2
US100	100cm	72cm	150kg	365l
US120	120cm	90cm	250kg	683,2l
US60	22,8"	17,53"	77lbs	21gal
US70	27,6"	19,7"	121lbs	32,6gal
US80	30,7"	26,8"	145lbs	37,1gal
US90	35,4"	26,8"	242lbs	65,7gal
US100	39,4"	28,3"	330lbs	96,4gal
US120	47,2"	35,4"	550lbs	180,5gal

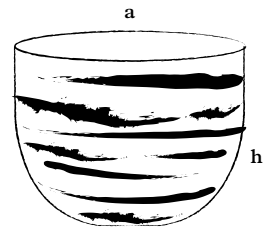

G/BL3



Z/BL3

UZ

	a	h	w	m ³
UZ60	58cm	44cm	35kg	79,4l
UZ70	70cm	50cm	55kg	123,5l
UZ80	78cm	68cm	65kg	140,4l
UZ90	90cm	68cm	110kg	248,2l
UZ100	100cm	72cm	150kg	365l
UZ120	120cm	90cm	250kg	683,2l

UZ60	22,8"	17,53"	77lbs	21gal
UZ70	27,6"	19,7"	121lbs	32,6gal
UZ80	30,7"	26,8"	145lbs	37,1gal
UZ90	35,4"	26,8"	242lbs	65,7gal
UZ100	39,4"	28,3"	330lbs	96,4gal
UZ120	47,2"	35,4"	550lbs	180,5gal

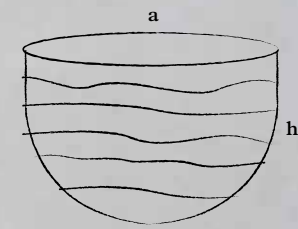



WP

	a	b	h	w
WP60	56cm	62cm	28cm	25kg

WP60	22"	24,4"	11"	55lbs
-------------	-----	-------	-----	-------

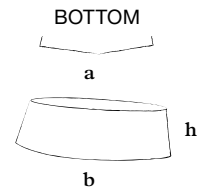

*Different colour combinations
are possible.*

Info upon request.



WPH

	a	b	h	w
WPH60	52cm	60cm	42cm	35kg

WPH60	20,5"	23,6"	16,5"	77lbs
--------------	-------	-------	-------	-------

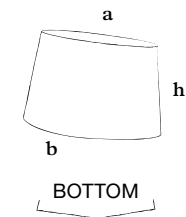



WPH



Composed of different rectangular shaped blocks, this Wall of Togetherness functions as a room spacer, where people share the same space — but work or play independently from each other — together apart.

WT

ZB

	a	b	c	h	w
ZB50	50cm	39cm	34cm	46cm	30kg
ZB60	53cm	42cm	37cm	51cm	40kg
ZB50	19,6"	15,3"	13,3"	18,1"	66,1lbs
ZB60	20,9"	16,5"	14,6"	20,1"	88,1lbs

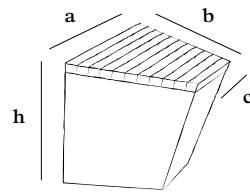

ZS



	a	h	w
ZS4555	45cm	54cm	45kg
ZS4070	40cm	69cm	50kg
ZS4555	17,7"	21,3"	99lbs
ZS4070	15,7"	27,2"	110lbs

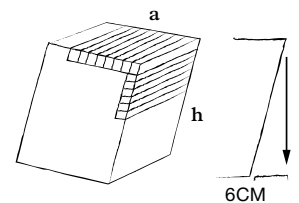

ZS

UF100 black
Suit Supply,
Chicago



ZSL

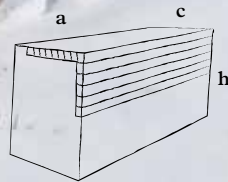

	a	c	h	w
ZSL90	90cm	40cm	45cm	90kg
ZSL90	35,4"	15,7"	17,7"	200lbs

VP



	a	c	h	w
VP1	50cm	17cm	21cm	10kg
VP2	50cm	16cm	21cm	10kg
VP1	19,7"	6,7"	8,2"	22lbs
VP2	19,7"	6,3"	8,2"	22lbs

VP2 is slightly conic.

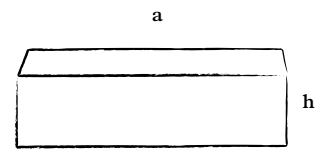

C

	a	h	w
C	50cm	26cm	15kg
C	19,7"	10,2"	35lbs

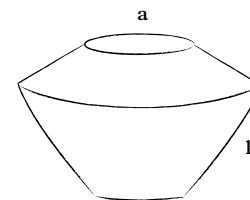

G

GB

	a	b	h	w
G	29cm	42cm	33cm	15kg
GB	29cm	42cm	33cm	15kg
G	11,4"	16,5"	13"	35lbs
GB	11,4"	16,5"	13"	35lbs

GB has a colour texture like shown on the image below.



Following bark textures are possible:

- White clay with grey texture*
- Grey clay with black texture*
- Black clay with red texture*
- Red clay with black texture*



FP/ FPL

	a	h	w
FP	46cm	29cm	15kg
FPL60	60cm	20cm	20kg
FPL80	80cm	20cm	45kg
FP	18,1"	11,4"	35lbs
FPL60	23,6"	7,9"	45lbs
FPL80	31,5"	7,9"	100lbs

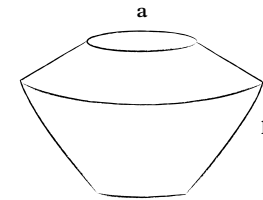

BATH TUB

Collaboration with
Studio LoHo



Studio LoHo was founded in 2017, as design collaboration between Karel Loontjens and Jo Hoeven. Karel runs Aardig Gedacht, an ecological construction company; Jo is interior architect. During Salone del Mobile in Milan in 2018, the duo presented for the first time 'the clay bath series'. Studio LoHo concentrates on interior projects with particular attention for custom works. The challenges they face during these projects generate as well new product designs, with accent on durability and natural, genuine materials.

Check for more details on available sizes and options.



BATH TUB LARGE

Design
Atelier Vierkant



BATH TUB LARGE

a	b	c	d	e	f	g	h	i	w
41cm	112cm	7cm	42cm	9cm	55cm	65cm	4cm	40cm	300kg
16,1"	44,1"	2,8"	16,5"	3,5"	21,7"	25,6"	1,6"	15,7"	660lbs

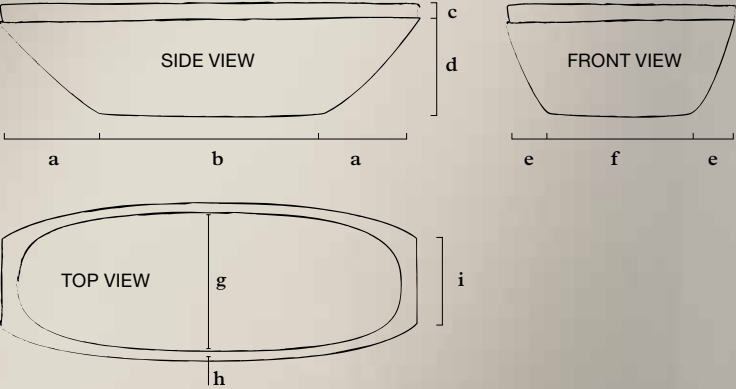

CREDITS

All photography:
Bart Van Leuven
www.bartvanleuven.com
unless other specified.

Joshua McHugh
page 35

Claudia Luperto
pages 41, 43, 114-115, 436, 500-501

Anai Ibarra
pages 442-443

Peter Ellery
pages 551,568

Allan Pollok-Morris
pages 566-567

Nuria Vila
pages 356, 399-341, 432-433, 495

Frassinago
pages 113, 344

Satoshi Shigeta
pages 298-299, 430-431, 437, 446-447

Kasia Gatkowska
pages 554-557

Wiseman Group
pages 43-44

Marion Brenner
pages 187, 427, 537

Dave Kulesza
page 542

Jan Verlinde
page 90, 552, 570

Nathalie Jouan
page 389

Rebecca Toh
pages 128,300-301, 416-417

Edward Hendricks
page 137, 313, 314

Joao Bessone
pages 96, 172-173

Raphael Oliver
pages 412-413

Shin Miura
page 420

Alister Thorpe
pages 422-423, 472-473

Pernilla Danielsson
pages 454, 524-525, 564

Stefan Altenburger
pages 502-503, 519

Aryeh Kornfeld
pages 414-415

Mariko Reed
pages 532-533

Undine Prohl
pages 37, 140, 369, 386, 452-453

Jakub Skokan
page 504

Molteni
page 227

Jason Oddy
page 250

One Abode
pages 496-497

Caroline Piek
page 499

Note: Since Atelier Vierkant products are handmade, Atelier Vierkant is not responsible for any mistake in this catalog on dimension or weight.

